

## Ford Ranger Super Duty (P703 2026-on) Predator & Toro Front Bar Fitting Instruction

### **IMPORTANT! – READ BEFORE INSTALLATION**

- When installed in accordance with these instructions, the front protection bar does not affect the operation of the vehicles SRS airbags.
- This product must be installed exactly as per these instructions using only hardware supplied.
- Take a few moments to read instructions thoroughly before beginning work.
- In the event of damage to any bar component please contact OFFROAD ANIMAL to arrange repair/replacement of components.
- Do not use this product for any vehicle make or model other than that specified on these instructions.
- Do not remove labels from this product.
- This product and its fixings must not be modified in any way unless stated in these fitting instructions.
- The installation of this product is recommended for trained personnel.
- These instructions are correct at time of publication. OFFROAD ANIMAL cannot be held responsible for the impact of any changes subsequently made by the vehicle manufacturer. If you find something has changed, please contact us to let us know!
- During installation it is the duty of the installer to check correct operation/clearances of all components.
- If Instructions are to be printed for reference in the workshop, it is recommended that they are printed in colour, for best legibility.

## GENERAL CARE AND MAINTENANCE

Use caution when cleaning with pressure washers, as they may compromise the product coating's integrity. Exercise care to avoid surface damage.

Only wash the product with a PH neutral car wash to prevent paint damage and discolouration.

Do not use acidic or alkaline based cleaning products.

Plastic parts may be maintained with silicone spray.

It is important to perform regular checks (pre/during/post trip or on an annual basis) on the installed product. More frequent checks may be required in extreme use cases. Checks include:

- Visual inspection for damage (eg. cracks, chips, dents etc.)
- Electrical wiring is not rubbing anything or worn out
- Bolts are torqued to correct specification (see torque guide below)

For touching up small stone chips, Offroad Animal recommends the following paint products:

- Dupli-Color Trim & Bumper Paint Black (TB101)
- VHT Hood, Bumper & Trim Paint Black (SP27)

## BOLT TORQUE SETTINGS

Use the following bolt torques on all general fasteners, unless otherwise specified.

| GENERAL FASTENERS |           |
|-------------------|-----------|
| Size              | Torque Nm |
| M5                | 5 Nm      |
| M6                | 9 Nm      |
| M8                | 22 Nm     |
| M10               | 44 Nm     |
| M12               | 77 Nm     |

Use the following bolt torques on all structural front bar mount and tow point fasteners, and rear towbar fasteners, unless otherwise specified.

| FRONT BAR MOUNTS AND TOW POINTS<br>+ REAR TOWBAR |           |
|--|-----------|
| Size   | Torque Nm |
| M10  | 57 Nm     |
| M12  | 100 Nm    |
| M14  | 164 Nm    |
| M16  | 248 Nm    |



**Always use a torque wrench to set correct torque settings. Ensure torque wrench is set to Nm unit of measurement. Otherwise perform conversion to lb-ft.**



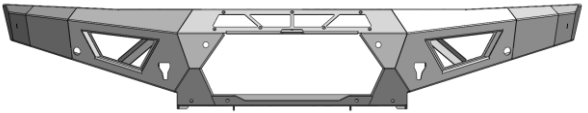
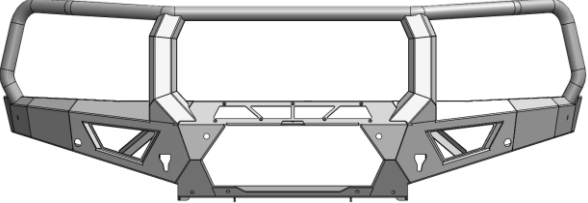
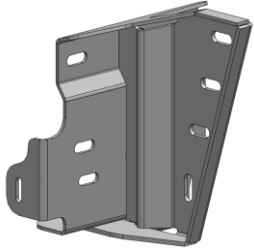
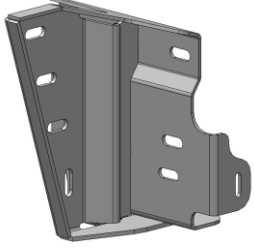
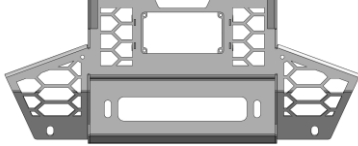
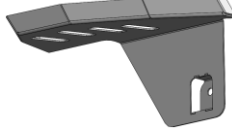
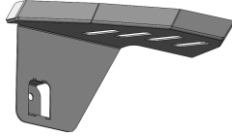

# PARTS LISTING

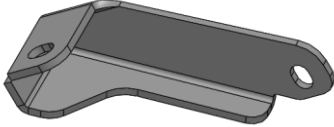
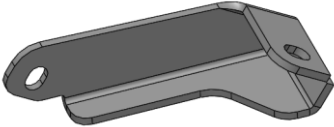
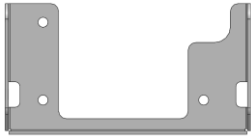

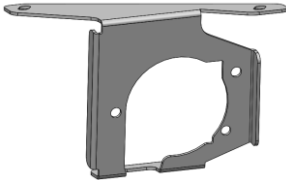
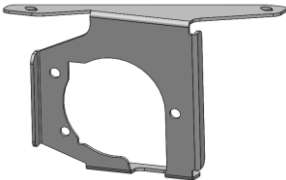
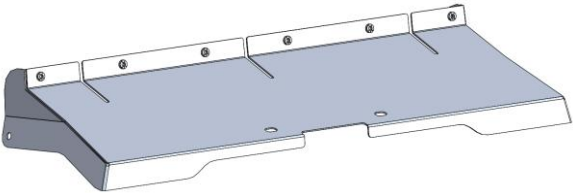
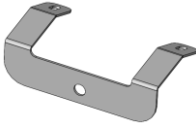

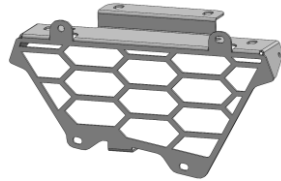
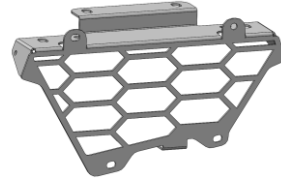
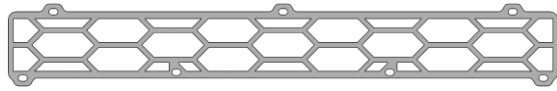
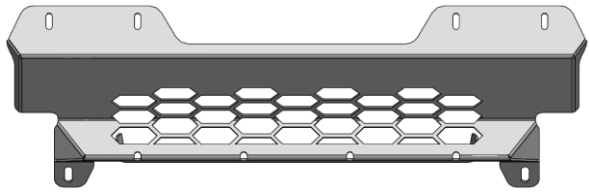
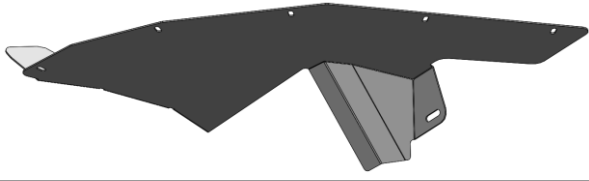
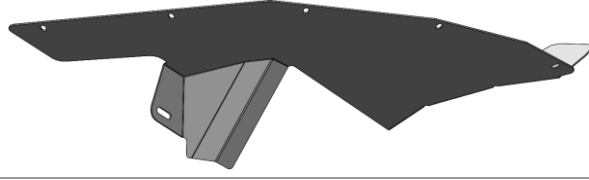

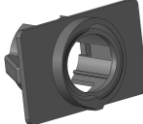
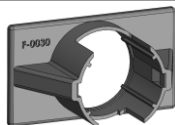
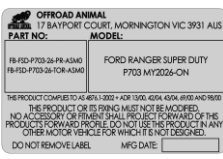
**IMPORTANT:** Check all parts are present before beginning work! Contact OFFROAD ANIMAL if something is missing.

## Main Parts – In the Box

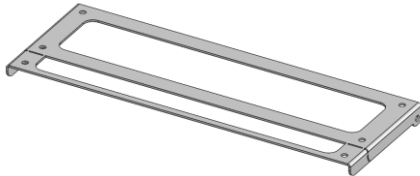
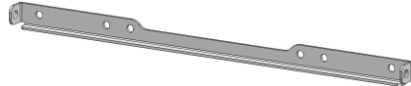
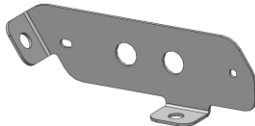
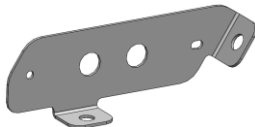
| Qty       | Part Number             | Description  | Image  |
|-----------|-------------------------|--|--|
| 1         | FB-FSD-P703-26-PR-ASM1  | P703 Ranger Super Duty Predator Bar Welded Assembly  |    |
| <b>OR</b> |                         |  |  |
| 1         | FB-FSD-P703-26-TOR-ASM1 | P703 Ranger Super Duty Toro Bar Welded Assembly      |    |
| 1         | FB-FSD-P703-26-PR-ASM2R | P703 Ranger Super Duty Impact Assembly RH            |  |
| 1         | FB-FSD-P703-26-PR-ASM2L | P703 Ranger Super Duty Impact Assembly LH            |  |
| 1         | FB-FSD-P703-26-PR-ASM4  | P703 Ranger Super Duty Mesh Fairlead Welded Assembly |  |
| 1         | FB-FSD-P703-26-PR-ASM6R | P703 Ranger Super Duty Flare Endcap RH               |  |
| 1         | FB-FSD-P703-26-PR-ASM6L | P703 Ranger Super Duty Flare Endcap LH               |  |

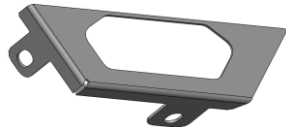
|   |         |   |  |
|---|---------|---|--|
| 1 | B-1406  | LC100/105 Pan Brace   |    |
| 2 | B-1818R | P703 Ranger Super Duty Chassis Brace                        |    |
| 2 | B-1818L | P703 Ranger Super Duty Chassis Brace                        |    |
| 1 | B-1819  | P703 Ranger Radar Mount                                     |    |
| 1 | B-1820  | P703 Ranger Super Duty Camera Mount                         |    |
| 1 | B-1821  | P703 Ranger Super Duty Camera Clamp                         |  |
| 1 | B-1823  | P703 Ranger Super Duty Camera Cover                         |  |
| 1 | B-1824R | P703 Ranger Super Duty Fog Light Bracket (3 Bolt) RH        |  |
| 1 | B-1824L | P703 Ranger Super Duty Fog Light Bracket (3 Bolt) LH        |  |
| 1 | B-1834  | P703 Ranger Super Duty Intercooler Air Guide                |  |
| 1 | B-1835  | P703 Ranger Super Duty Intercooler Air Guide Centre Support |  |

|   |                          |   |   |
|---|--------------------------|---|---|
| 1 | M-0087R                  | P703 Ranger Super Duty Wing Mesh RH                     |     |
| 1 | M-0087L                  | P703 Ranger Super Duty Wing Mesh LH                     |     |
| 1 | P-0515                   | 22" Lightbar Mesh Infill Plate                          |     |
| 1 | U-0135                   | P703 Ranger Super Duty Bash Plate                       |     |
| 1 | U-0136R                  | P703 Ranger Super Duty Side Underpanel RH               |    |
| 1 | U-0136L                  | P703 Ranger Super Duty Side Underpanel LH               |   |
| 1 | F-0013R                  | Ford Ranger Next Gen Sensor Holder - 11 Deg Vertical RH |  |
| 1 | F-0013L                  | Ford Ranger Next Gen Sensor Holder - 11 Deg Vertical LH |  |
| 2 | F-0030                   | Parking Sensor Holder - Universal, Flat                 |   |
| 1 | FB-FSD-P703-26-PR-ADRCP  | ADR Compliance Plate Ford Ranger Super Duty P703        |   |
| 4 | Fir Tree Clip 4.5mm Hole | Fine-rib push-in rivet, WURTH 0500827023                |  |

|  |               |   |   |
|--|---------------|---|---|
| 1  | N-0027        | P703 Ranger Plastic Radar Cover                             |     |
| 1  | TK-COM-PSEN-4 | Tape Kit - 4 Sensor Universal                               | N/A   |
| <b>NUMBER PLATE FLIP ASSEMBLY (NPF-COM-LGE-ASM0)</b> |               |   |   |
| 1  | B-1446        | Number Plate Flip - Large                                   |     |
| 1  | B-1458        | Number Plate Flip Base                                      |     |
| <b>INDICATOR REPEATER PARTS</b>                      |               |   |   |
| 1  | B-1827R       | P703 Ranger Super Duty Indicator Repeater Clamp Bracket RH  |     |
| 1  | B-1827L       | P703 Ranger Super Duty Indicator Repeater Clamp Bracket LH  |    |
| 1  | B-1828R       | P703 Ranger Super Duty Indicator Repeater Housing RH        |   |
| 1  | B-1828L       | P703 Ranger Super Duty Indicator Repeater Housing LH        |   |
| 2  | P-0544        | P703 Ranger Super Duty Indicator Repeater Shim Plate - Main |   |
| 1  | 11CAT1M-2     | LED Autolamps 11CAT1M-2 Front Indicator - Twin Blister Pack |   |
| <b>TORO ONLY</b>                                     |               |   |   |
| 1  | B-1830R       | P703 Ranger Super Duty Toro Antenna Bracket RH              |  |
| 1  | B-1830L       | P703 Ranger Super Duty Toro Antenna Bracket LH              |  |

**Fasteners – Contained in Small Parts Kit Bag**

| Qty | Part Number                                      | Description  |
|-----|--|--|
| 4   | M3X16 PAN  | SCREW, PAN HEAD PHILLIPS, M3X16X0.5 GR4.6 ZP   |
| 4   | M3 FLAT WASHER                                   | Flat Washer M3, 7mmODx0.5mm T  |
| 4   | M3 NYLOC   | NYLOC SELF LOCKING NUT, ST STL A2 ISO  |
| 6   | M4 X 10 HEX                                      | M4X10 HEX BOLT, ZP, 4.6  |
| 6   | M4 FLAT WASHER                                   | Flat Washer M4, 8mmODx0.8mm T  |
| 14  | M6 X 12 HEX                                      | M6X12 HEX BOLT, ZP, 8.8  |
| 3   | M6 X 20 HEX                                      | M6X20 HEX BOLT, ZP, 8.8  |
| 12  | M6x12 BHCS BLACK ZINC                            | SCREW, BUTTON HEAD CAP, M6X12X1 GR12.9, ISO4042 ZnNi BLACK PASSIVATED FINISH                 |
| 26  | M6x16 BHCS BLACK ZINC                            | SCREW, BUTTON HEAD CAP, M6X16X1 GR12.9, ISO4042 ZnNi BLACK PASSIVATED FINISH                 |
| 7   | M6 X 12 CSK BZP                                  | SCREW, COUNTERSUNK CAP, M6X12X1 Black ZP   |
| 2   | M6 X 16 PAN POZI THREAD FORMING SCREW BLACK ZINC | DIN 7500 PLASTIC THREAD FORMING SCREW, PAN POZI, M6X16, ISO4042 ZnNi BLACK PASSIVATED FINISH |
| 17  | M6 FLAT WASHER                                   | M6 FLAT WASHER   |
| 38  | M6 FLAT WASHER BLACK ZINC                        | M6 Flat Washer, 12x6.1x1, ISO4042 ZnNi BLACK PASSIVATED FINISH                               |
| 36  | M6 FLANGE NUT                                    | Flange Nut, M6x1 G8.8 ZP   |
| 2   | M6CN2MM  | CAGE NUT M6x1.6-2.5  |
| 10  | M6CN3MM  | CAGE NUT M6x2.6-3.5  |
| 2   | M8 X 20 HEX                                      | Bolt Hex, M8X20x1.25, GR8.8 ZP   |
| 2   | M8 X 16 BHCS BZP                                 | SCREW, BUTTON HEAD CAP, M8X16X1.25 GR12.9, ISO4042 ZnNi BLACK PASSIVATED FINISH              |
| 2   | M8 X 20 BHCS BLACK ZINC                          | SCREW, BUTTON HEAD CAP, M8X20X1.25, ISO4042 ZnNi BLACK PASSIVATED FINISH                     |
| 4   | M8 X 30 BHCS BLACK ZINC                          | SCREW, BUTTON HEAD CAP, M8X30X1.25, ISO4042 ZnNi BLACK PASSIVATED FINISH                     |
| 2   | M8 HD FLAT WASHER                                | M8 FLAT WASHER - High Tensile 19x8x1.9mm   |
| 8   | M8 HD FLAT WASHER - BZP                          | M8 FLAT WASHER - High Tensile 19x8x2mm, ISO4042 ZnNi BLACK PASSIVATED FINISH                 |
| 2   | M8 FLANGE NUT                                    | Flange Nut, M8x1.25 G8.8 ZP  |
| 2   | M10 x 25   | Bolt Hex, M10X25x[1.5], GR8.8 ZP   |
| 4   | M10 X 40   | Bolt Hex, M10X40X1.5, GR8.8 ZP   |
| 2   | M10 X 100  | Bolt Hex, M10X100X1.5, GR8.8 ZP  |
| 8   | M10 FW LHD                                       | WASHER, FLAT M10X28.5X2.5  |
| 8   | M10 FLANGE NUT                                   | Flange Nut, M10x1.5 G8.8 ZP  |
| 12  | M12X30   | Bolt Hex, M12X30x1.75, GR8.8 ZP  |
| 4   | M12X40   | Bolt Hex, M12X40X1.75, GR8.8 ZP  |
| 18  | M12 FW LHD                                       | M12 FW Large Heavy Duty  |
| 14  | M12 FLANGE NUT                                   | Flange Nut, M12x1.75 G8.8 ZP   |
| 2   | M12 NYLOC NUT                                    | M12 NYLOC NUT  |
| 8   | P-0551   | P703 Ranger Super Duty Impact Assembly Spacer 6mm  |
| 2   | T-0174   | Crush Tube 60mm L, 16mm OD x 1.6 WT  |

**NUMBER PLATE FLIP Fasteners – Contained in Number Plate Flip Kit**

| Qty | Part Number               | Description  |
|-----|---------------------------|--|
| 4   | M6x12 BHCS BLACK ZINC     | SCREW, BUTTON HEAD CAP, M6X12X1 GR12.9, ISO4042 ZnNi BLACK PASSIVATED FINISH |
| 4   | M6x16 BHCS BLACK ZINC     | SCREW, BUTTON HEAD CAP, M6X16X1 GR12.9, ISO4042 ZnNi BLACK PASSIVATED FINISH |
| 10  | M6 FLAT WASHER BLACK ZINC | M6 Flat Washer, 12x6.1x1, ISO4042 ZnNi BLACK PASSIVATED FINISH               |
| 6   | M6 FLANGE NUT             | Flange Nut, M6x1 G8.8 ZP   |
| 2   | M6 NYLON WASHER           | Nylon Flat Washer, M6x12x1mm   |
| 2   | M6 NYLOC                  | NYLOC SELF LOCKING NUT, ST STL A2 ISO  |

**TORO ANTENNA Fasteners – Contained in Small Parts Kit Bag**

| Qty | Part Number             | Description  |
|-----|-------------------------|--|
| 4   | M8 X 20 BHCS BLACK ZINC | SCREW, BUTTON HEAD CAP, M8X20X1.25, ISO4042 ZnNi BLACK PASSIVATED FINISH     |
| 4   | M8 HD FLAT WASHER - BZP | M8 FLAT WASHER - High Tensile 19x8x2mm, ISO4042 ZnNi BLACK PASSIVATED FINISH |

## TOOLS REQUIRED

The following tools will be required to install the product.

| <b>Hand Tools</b>             | <b>Power Tools</b>                              | <b>Workshop Equipment</b>         |
|-------------------------------|---|-----------------------------------|
| Metric Socket Set 5.5-19mm    | Electric/Air Impact Driver (Optional)           | Panel Stand<br>or<br>Soft Blanket |
| Socket Extension Bar          | Electrical/Air Drill                            | Lifting Trolley                   |
| Metric Spanner Set 5.5-19mm   | Air Hacksaw<br>or<br>Jigsaw<br>or<br>Multi-tool | Isopropyl Alcohol                 |
| Hex (Allen) Key Set 4-6mm     | Angle Grinder                                   | Rag                               |
| T25 Torx bit                  |   | Cable Ties                        |
| Trim Removal Tool             |   | Marker Pen                        |
| Plastic Auto Trim Tool Set    |   | Ruler                             |
| Flat Blade Screwdriver Set    |   | Measuring Tape                    |
| Phillips Head Screwdriver Set |   | Masking Tape                      |
| Utility Knife                 |   | Sikaflex Adhesive                 |
| Side Cutters                  |   | Bucket                            |
| Pliers                        |   | Digital angle gauge               |
| Hose Line Clamp               |   | Black spray paint                 |
| Deburring Tool                |   |                                   |
| 2mm/5mm/6mm/7mm Drill Bits    |   |                                   |

# WORKSHOP SAFETY

It is the responsibility of the installer to always complete works in a safe manner. Make sure the following safety equipment is available and precautions are observed whilst fitting this product.

|   |  |
|---|--|
| <p>Hearing Protection</p>  | <p>Always wear ear protection when using power tools.</p>  |
| <p>Eye Protection</p>      | <p>Ensure eye protection is always worn when cutting or drilling.</p>  |
| <p>Manual Handling</p>   | <p>Do not attempt to lift bar assemblies or rock sliders on your own.</p> <p>Always use two people to lift or use mechanical Lifting aid such as hydraulic lifting trolley.</p>                          |
| <p>Vehicle Support</p>   | <p>Always ensure vehicle is properly supported when working on it. Do not attempt to fit products whilst suspension work is being carried out. Do not work under a vehicle supported only by a jack.</p> |



**WARNING**

**DO NOT** turn on or move car whilst any camera or radar systems are disconnected.

Failure to observe this precaution will result in system errors that will need car to be taken to Ford Dealership to resolve.

Keep proximity keys away from vehicle and out of range to minimise the chances of computers activating whilst modules are disconnected.

1. Remove number plate and set aside.

**TOOLS REQUIRED**

Phillips head screwdriver

**FASTENERS**

2x screws

Discard



2. Remove 8x plastic push clips holding the top of the plastic bumper trim.
- Use a flat blade screwdriver or trim tool to release the clips.

**TOOLS REQUIRED**

Flat blade screwdriver  
or  
Trim Tool

**FASTENERS**

8x push clips  
  
Discard

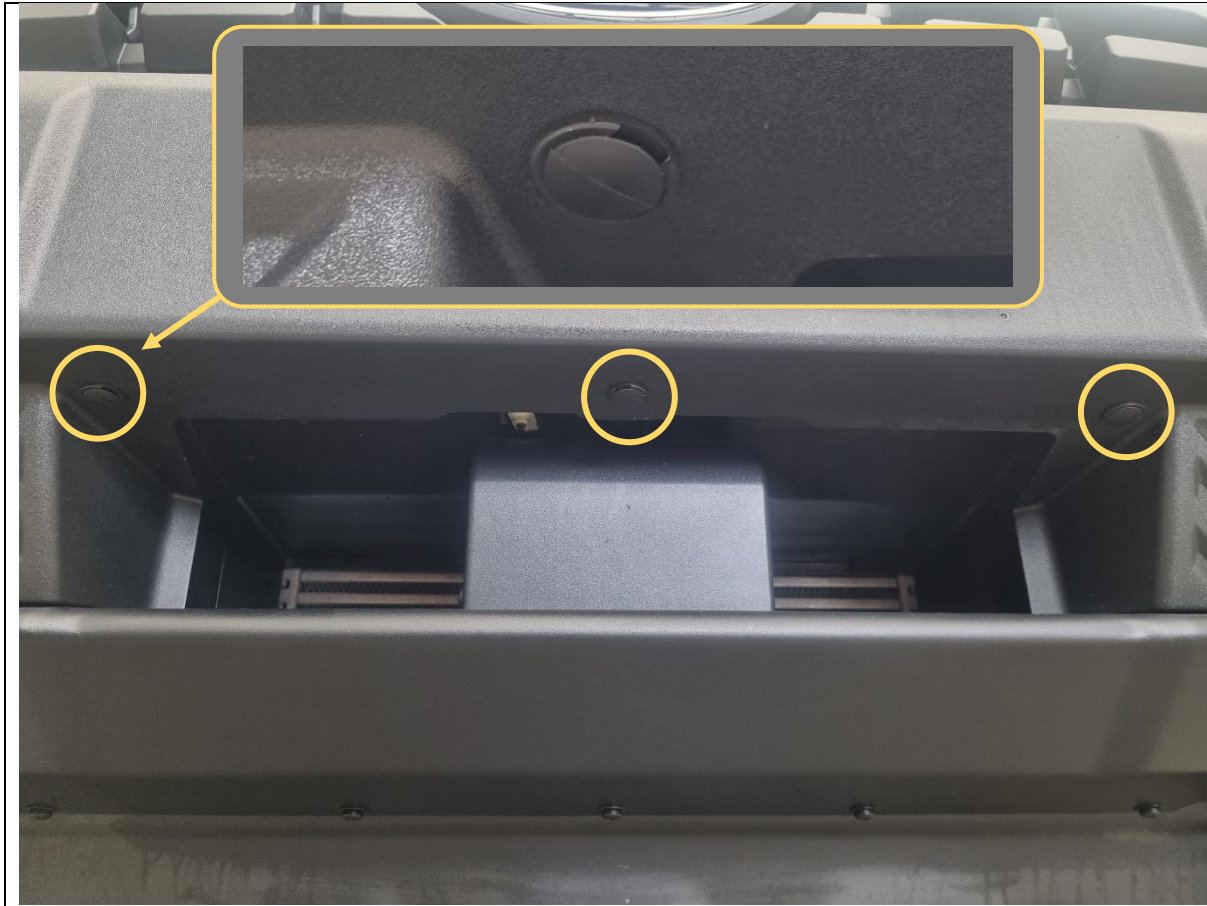

3. Remove 3x plastic push clips holding the bottom of the plastic bumper trim.

Use a flat blade screwdriver or trim tool to release the clips.

**Retain 1x clip for re-use.**

**TOOLS REQUIRED**

Flat blade screwdriver  
or  
Trim Tool

**FASTENERS**

3x push clips

**Retain 1x**



4. Start from both outer ends and pull the plastic bumper trim outwards to release the clips holding it to the vehicle.
5. Disconnect the parking sensor harness on the LH passenger side from the main bumper harness.
6. Set the plastic bumper trim aside for removing/relocating parking sensors later.

**TOOLS REQUIRED**

**FASTENERS**

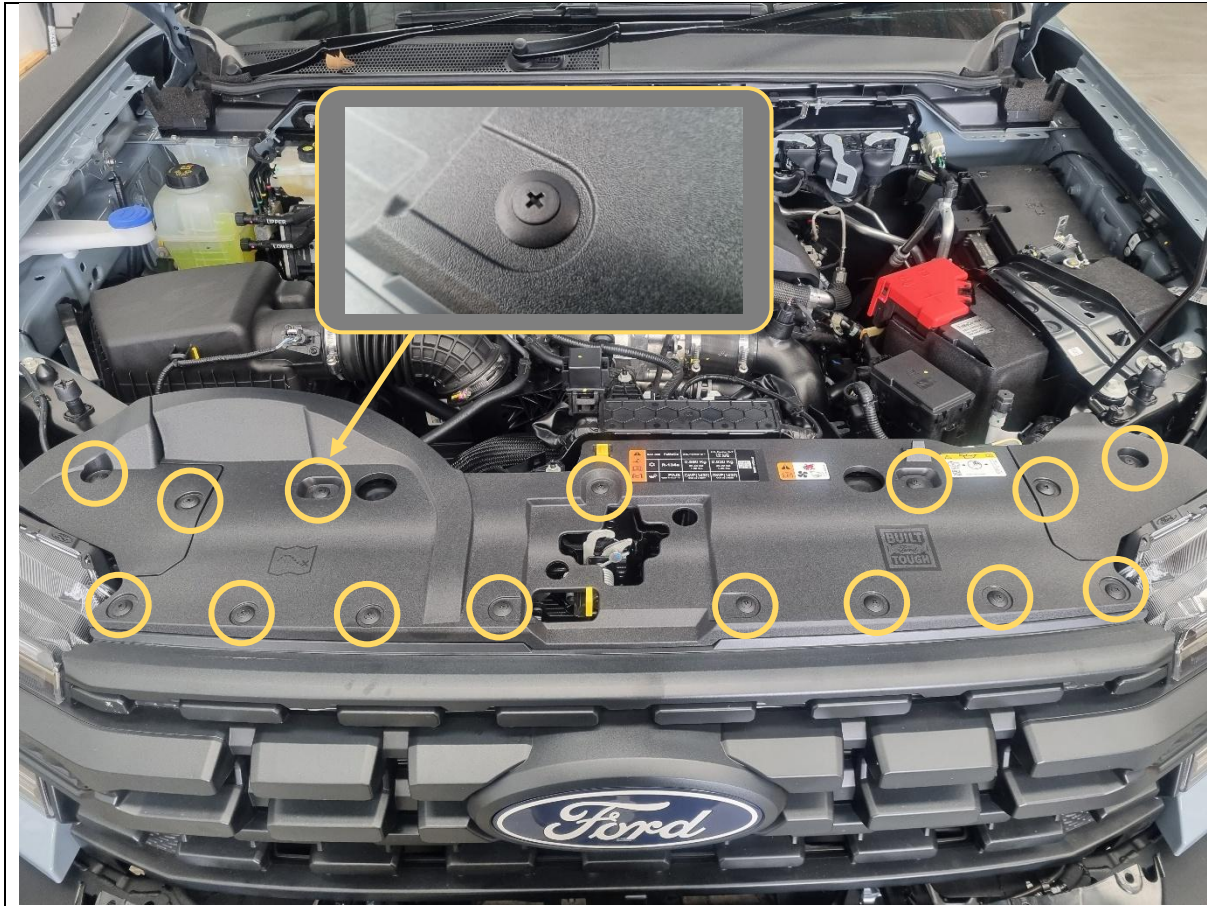

7. Open the bonnet. The bonnet release handle is on the LH passenger side.
  8. Remove 15x scrivets holding the radiator top cover and set aside.
- Use a Phillips head screwdriver to unscrew the head of the scrivet, then use a flat head screwdriver or trim tool to lift up and remove the scrivet.

**TOOLS REQUIRED**

Phillips head screwdriver  
Flat head screwdriver  
or  
Trim tool

**FASTENERS**

15x scrivets  
Retain

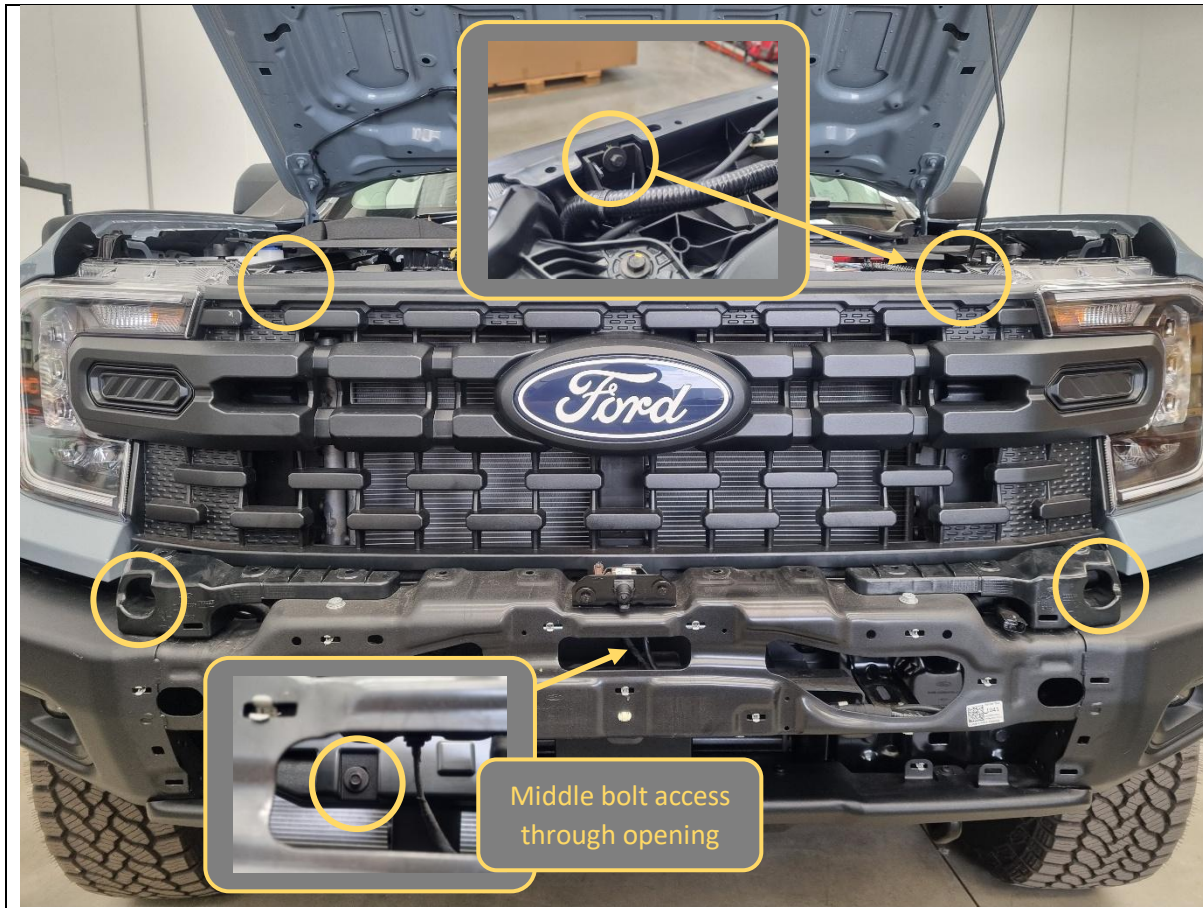

9. Remove 5x 8mm hex bolts (2x top, 3x bottom) holding the grille.

A socket extension is required for the bottom 3x bolts.

**TOOLS REQUIRED**

8mm socket/spanner  
Socket extension bar

**FASTENERS**

5x factory 8mm hex bolt

Retain



10. Start from the outer corners and firmly pull the grille outwards to release the clips holding it to the vehicle. Set aside in a safe place.

**TOOLS REQUIRED**

**FASTENERS**

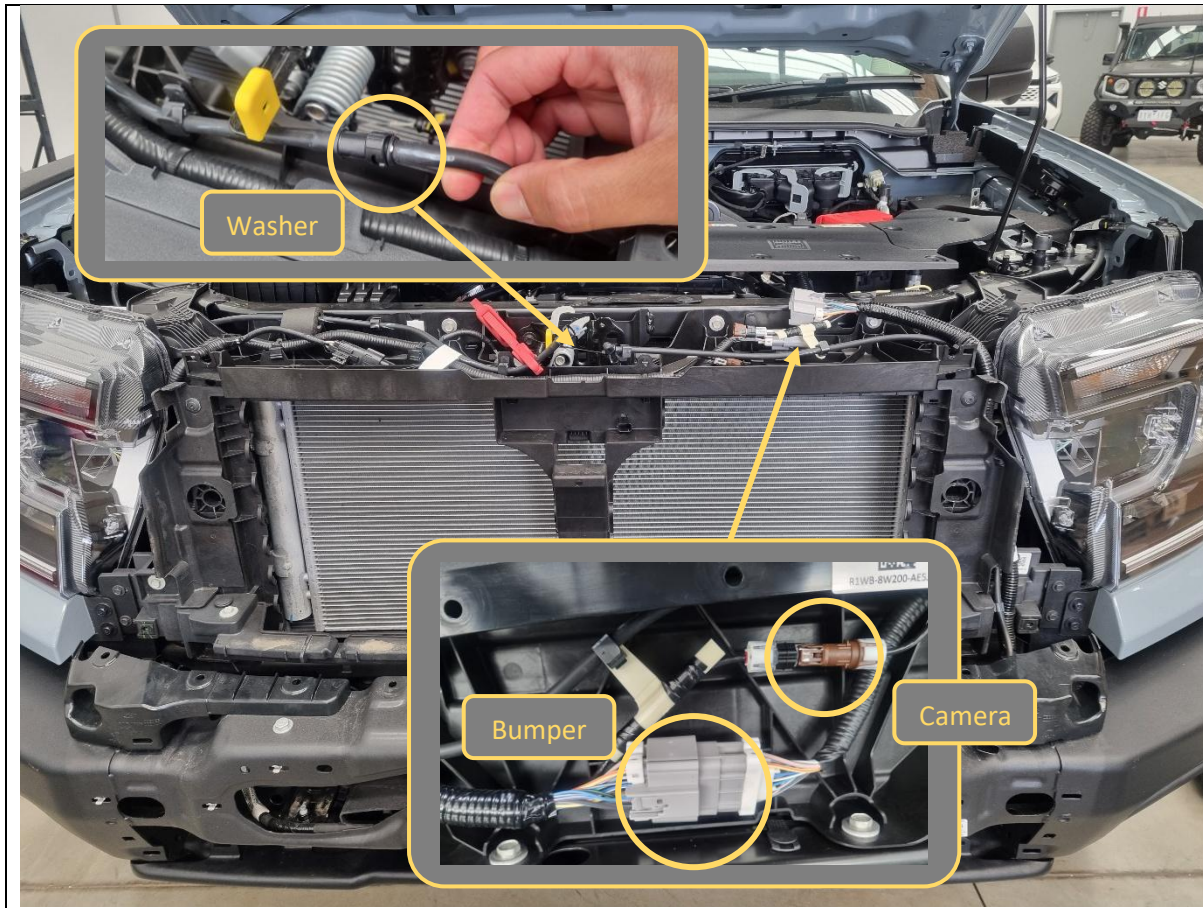

11. Disconnect the main bumper harness and camera harness at the top.
12. Either clamp the camera washer hose either side of the connector with cable ties and/or hose line clamps, or place a bucket underneath to let washer fluid drain out (this needs to be re-filled at the end, see maintenance section of Ford owner's manual).
13. Disconnect the camera washer hose.

**TOOLS REQUIRED**

Cable ties  
or  
Hose line clamp  
or  
Bucket

**FASTENERS**

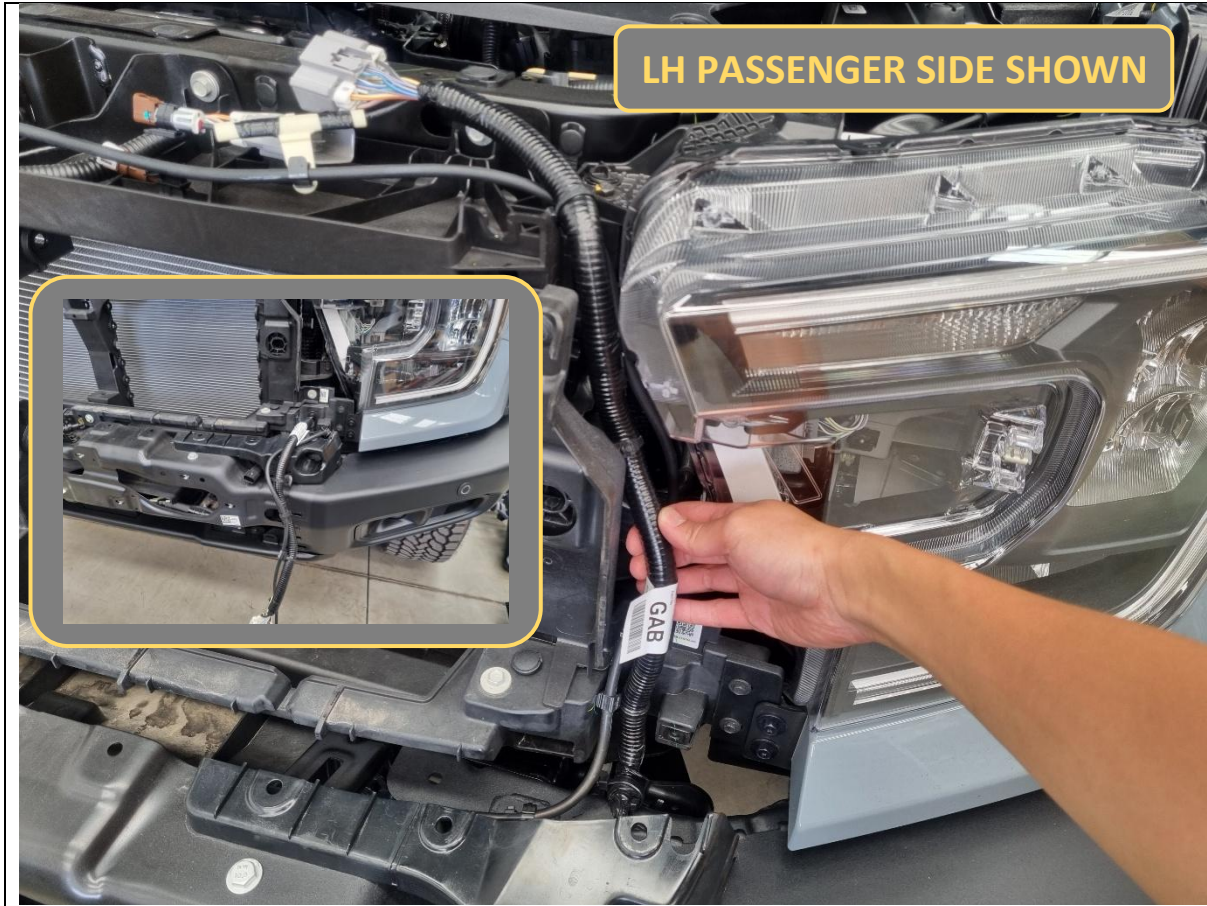

14. Unclip the bumper/camera harness and washer hose from the vehicle all the way down on the LH passenger side until you reach the steel bumper.

**TOOLS REQUIRED**

Trim tool

**FASTENERS**

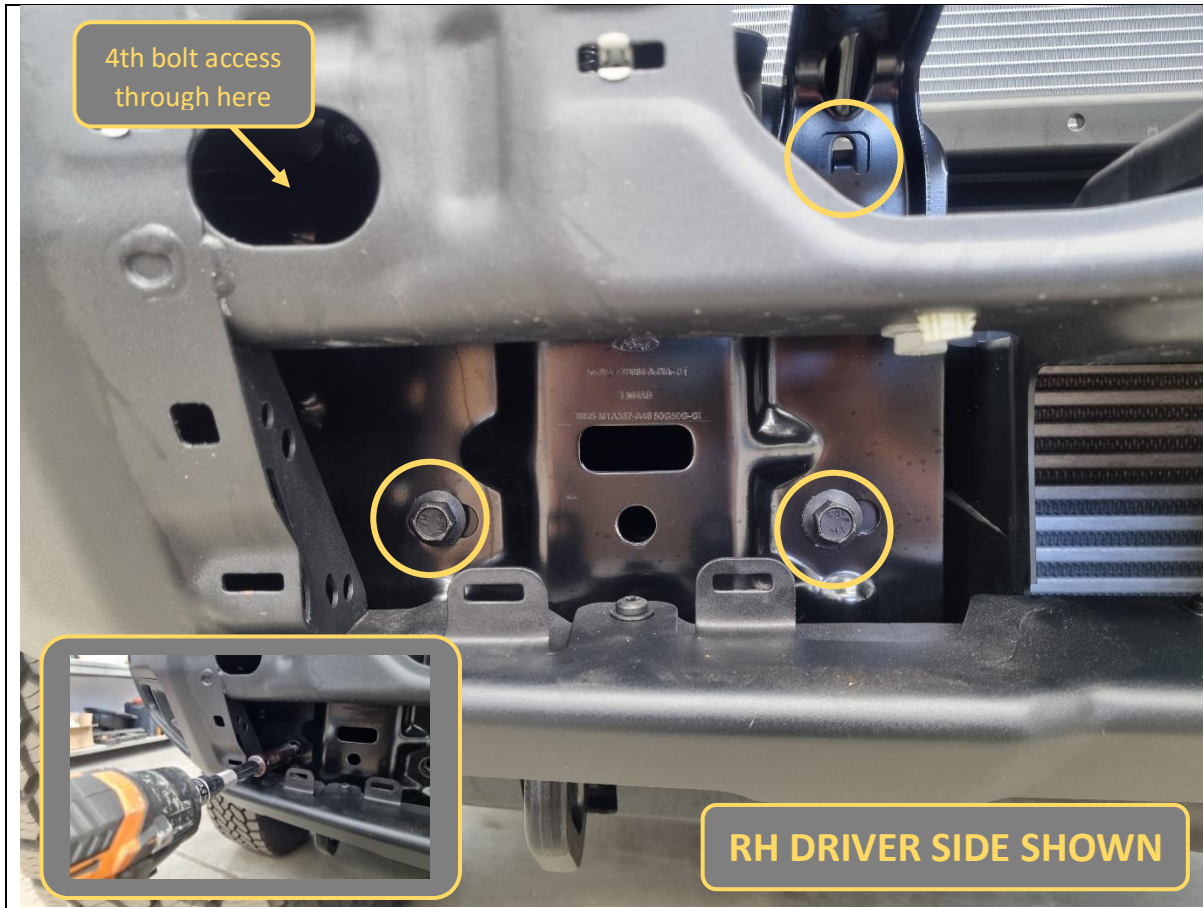

15. Remove 8x 15mm hex bolts (4x per side) holding the steel bumper to the chassis.

A socket extension bar is required.

**TOOLS REQUIRED**

15mm socket  
Socket extension bar

**FASTENERS**

8x factory 15mm hex bolts

Discard



16. Remove the steel bumper and set aside.

**TOOLS REQUIRED**

**FASTENERS**

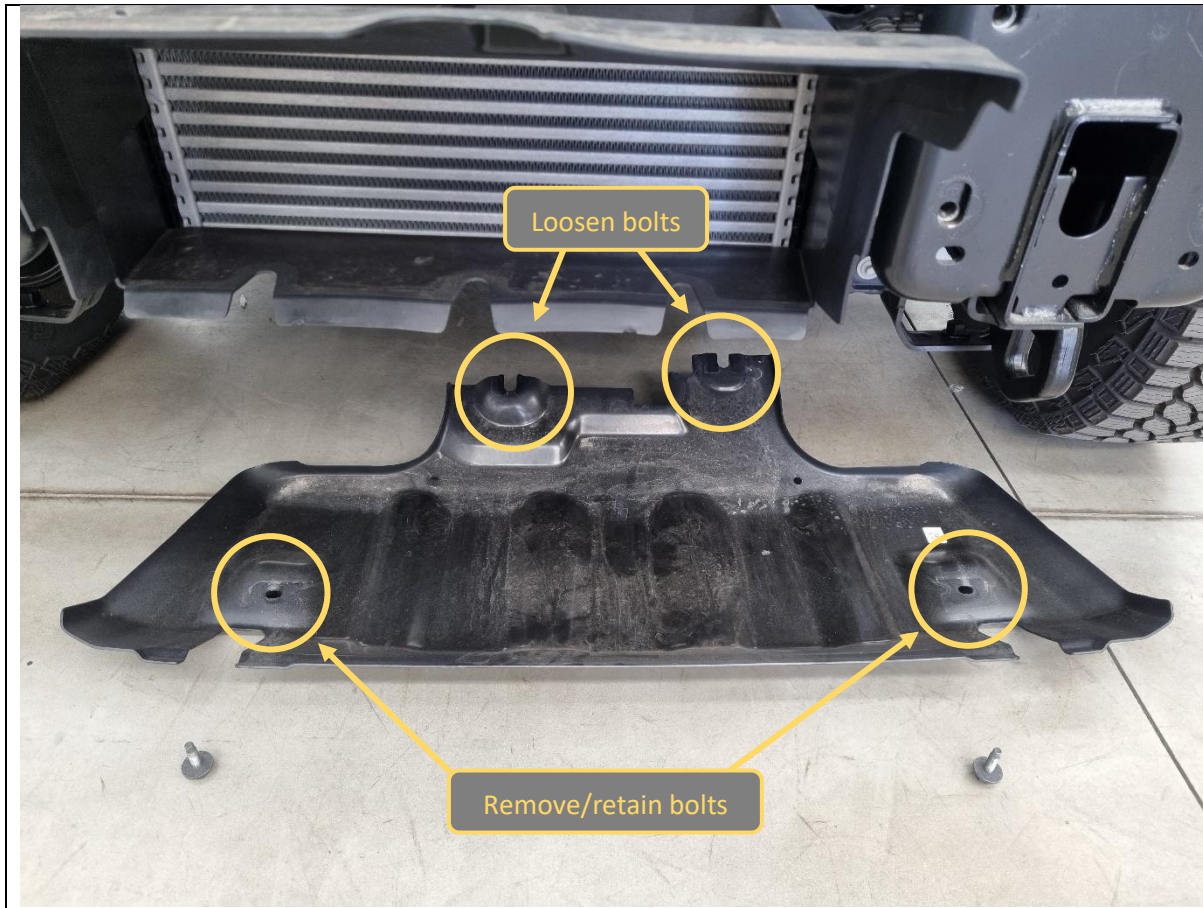

17. Remove 2x 15mm hex bolts holding the front of the factory bash plate.

Retain these bolts.

18. Loosen 2x 15mm hex bolts holding the rear of the factory bash plate.

19. Slide the factory bash plate out and set aside for later.

**TOOLS REQUIRED**

15mm socket/spanner

**FASTENERS**

2x factory 15mm hex bolt

Retain

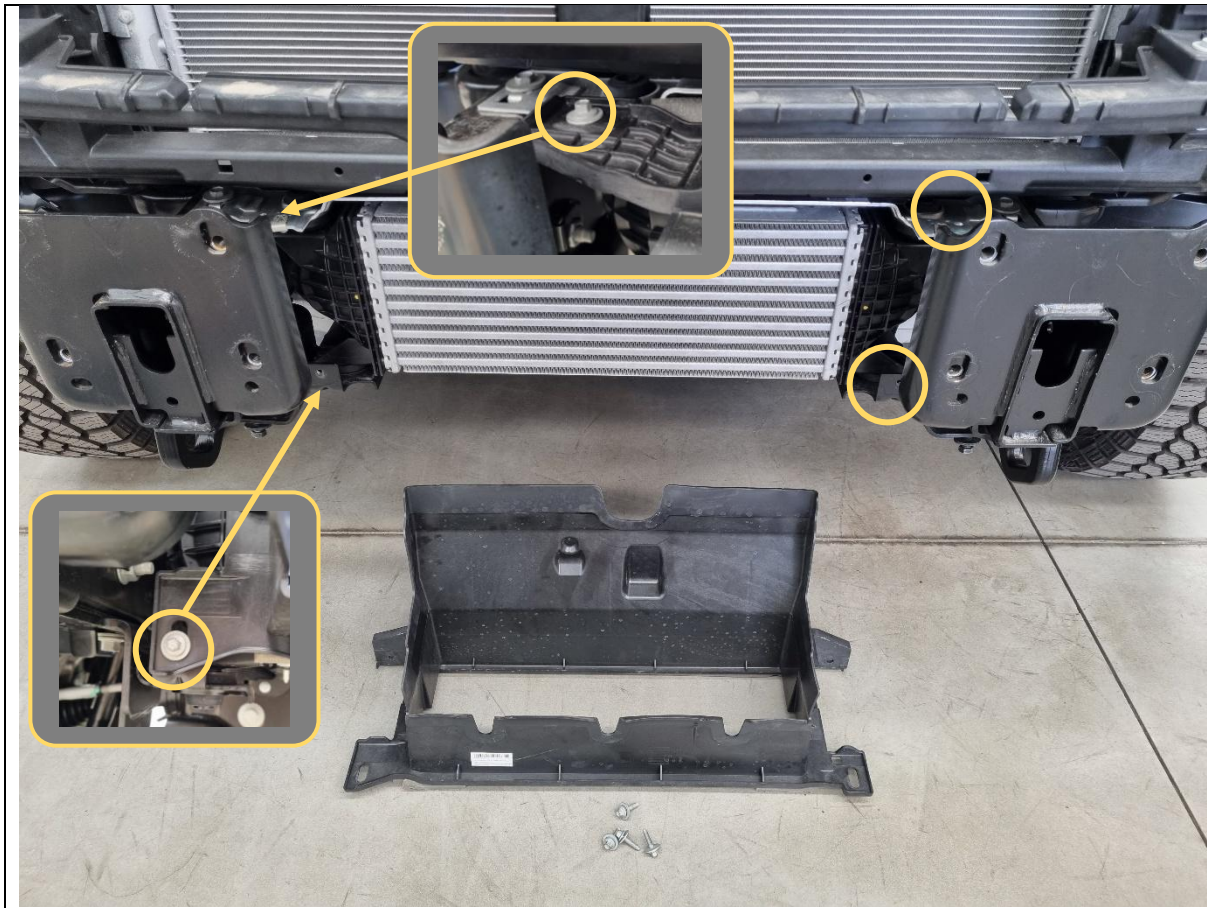

20. Remove 4x 8mm hex bolts holding the intercooler shroud.

21. Remove shroud and set aside. Retain bolts.

**TOOLS REQUIRED**

8mm socket/spanner

**FASTENERS**

4x factory 8mm hex bolt

Retain

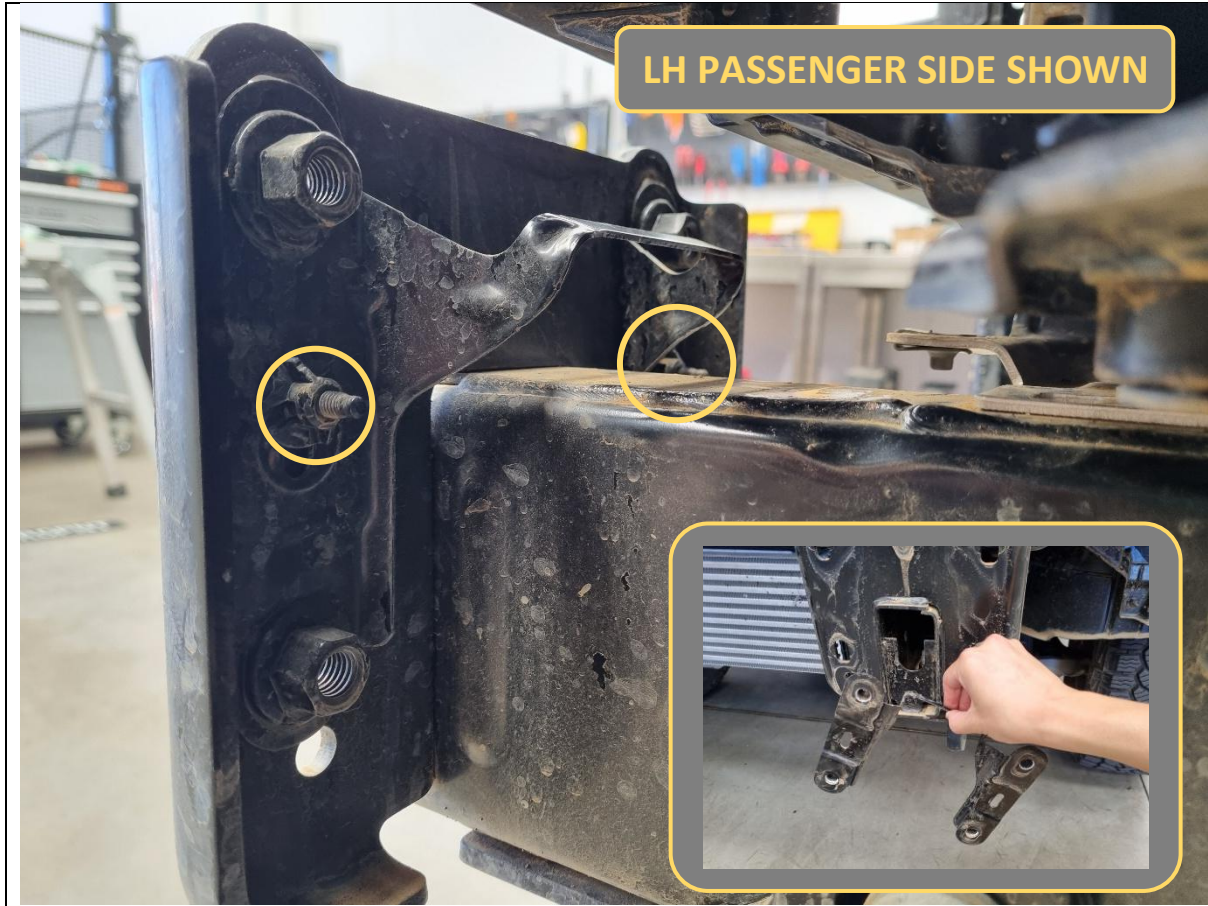

22. Remove 2x wing nuts holding each of the nut plates behind the chassis horn. Discard the nut plates.

**TOOLS REQUIRED**

**FASTENERS**

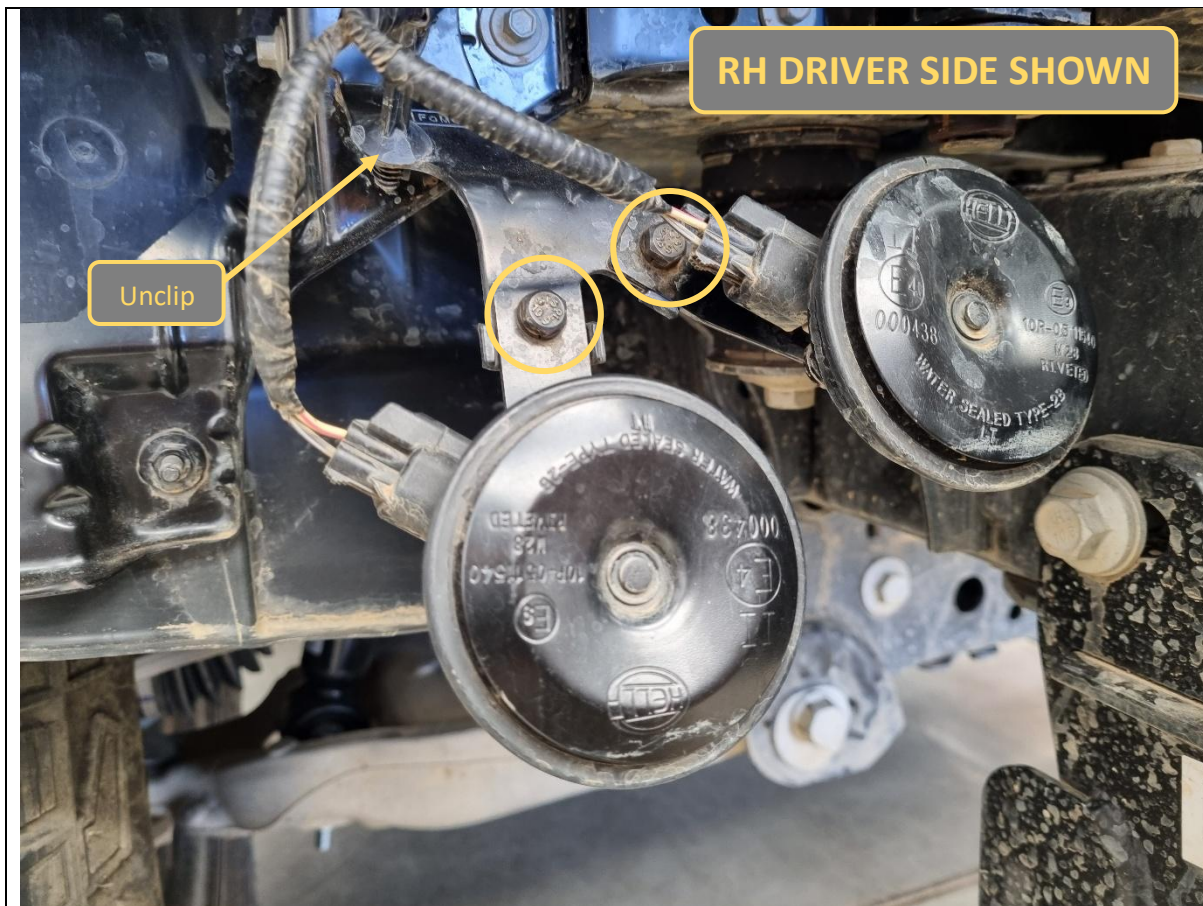

23. On the RH driver side, remove 1x 10mm hex bolt and nut holding each of the horns. Let the horns hang loose and discard the fasteners.

Note: You may need to disconnect one of the horns for tool access.

24. Also unclip the horn loom from the mounting bracket (see arrow).

**TOOLS REQUIRED**

10mm socket/spanner

Trim tool  
or  
Flat blade screwdriver

**FASTENERS**

Discard

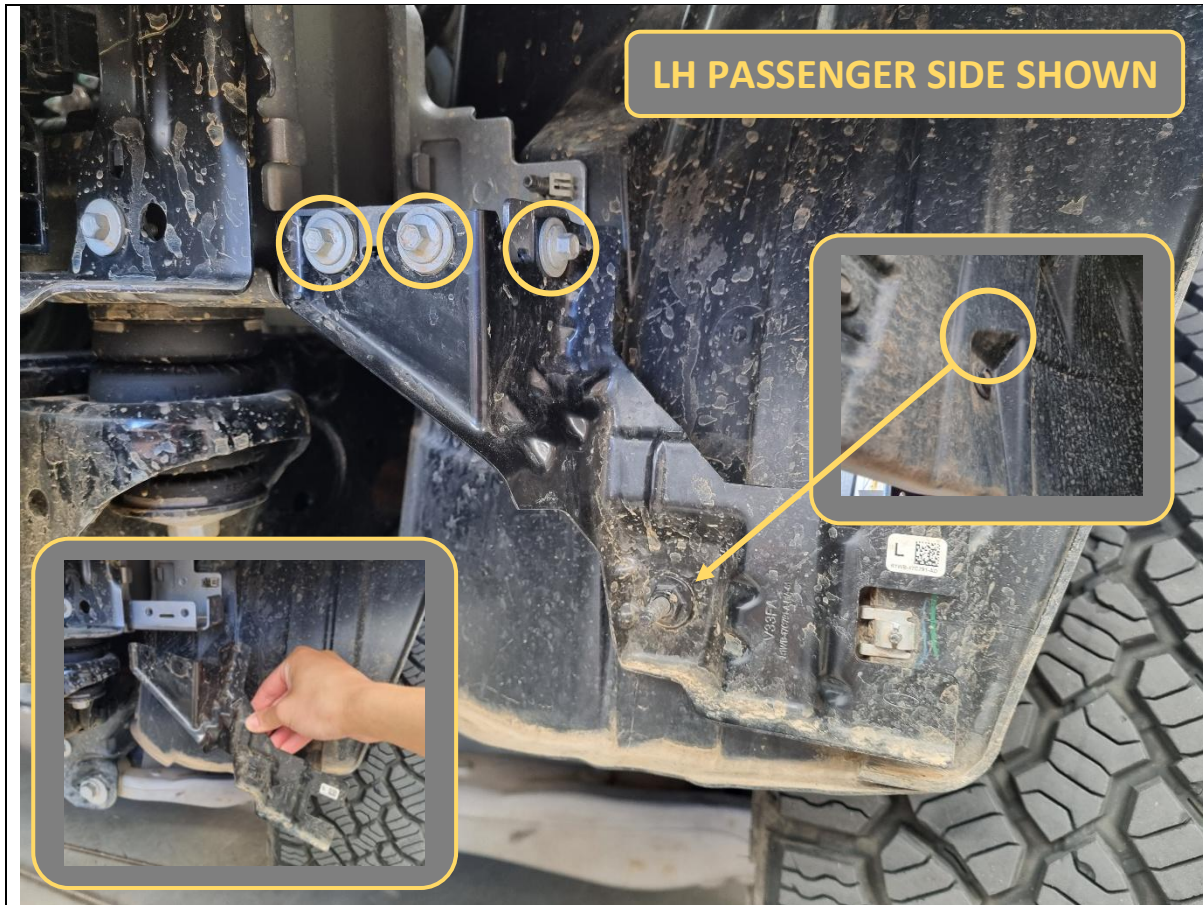

- 25. Remove 3x 8mm hex bolts and 1x 10mm hex bolt holding each wheel arch liner support bracket.
- 26. Keep the 8mm hex bolts and discard the bracket + 10mm hex bolts.

**TOOLS REQUIRED**

- 8mm socket/spanner
- 10mm socket/spanner

**FASTENERS**

- 6x factory 8mm hex bolt  
**Retain**
- 2x factory 10mm hex bolt  
Discard



**RH DRIVER SIDE SHOWN**

- 27. Flip the horns upside down from original orientation and re-mount them to where the wheel arch liner support bracket was bolted to with the 8mm factory hex bolts.
- 28. Fit the remaining 8mm hex bolts into any leftover wheel arch liner support bracket holes on both sides.

**TOOLS REQUIRED**  
8mm socket/spanner

**FASTENERS**  
6x factory 8mm hex bolt  
Retained from Step 25



29. The front of the flares needs to be trimmed. Apply masking tape over the approximate area shown.

**TOOLS REQUIRED**

Masking tape

**FASTENERS**

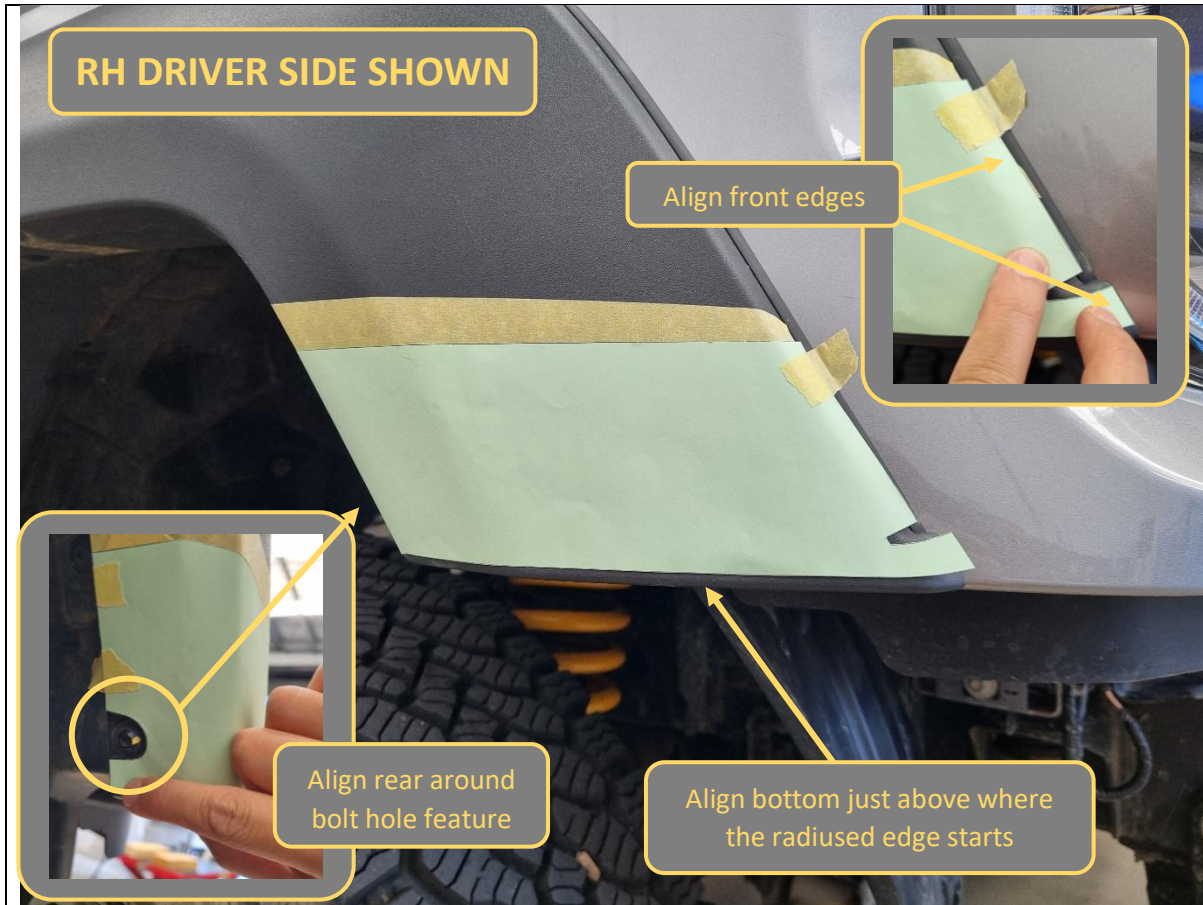

30. Go to [https://offroadanimal.com.au/content/P703 Ranger Super Duty Flare Cut Template.pdf](https://offroadanimal.com.au/content/P703_Ranger_Super_Duty_Flare_Cut_Template.pdf) to download and print the flare cut template. Make sure to print at 100% scale on A4 paper and cut out the profile.

31. Align the template onto the flare as shown. Hold in place with masking tape.

**TOOLS REQUIRED**

Masking tape

**FASTENERS**

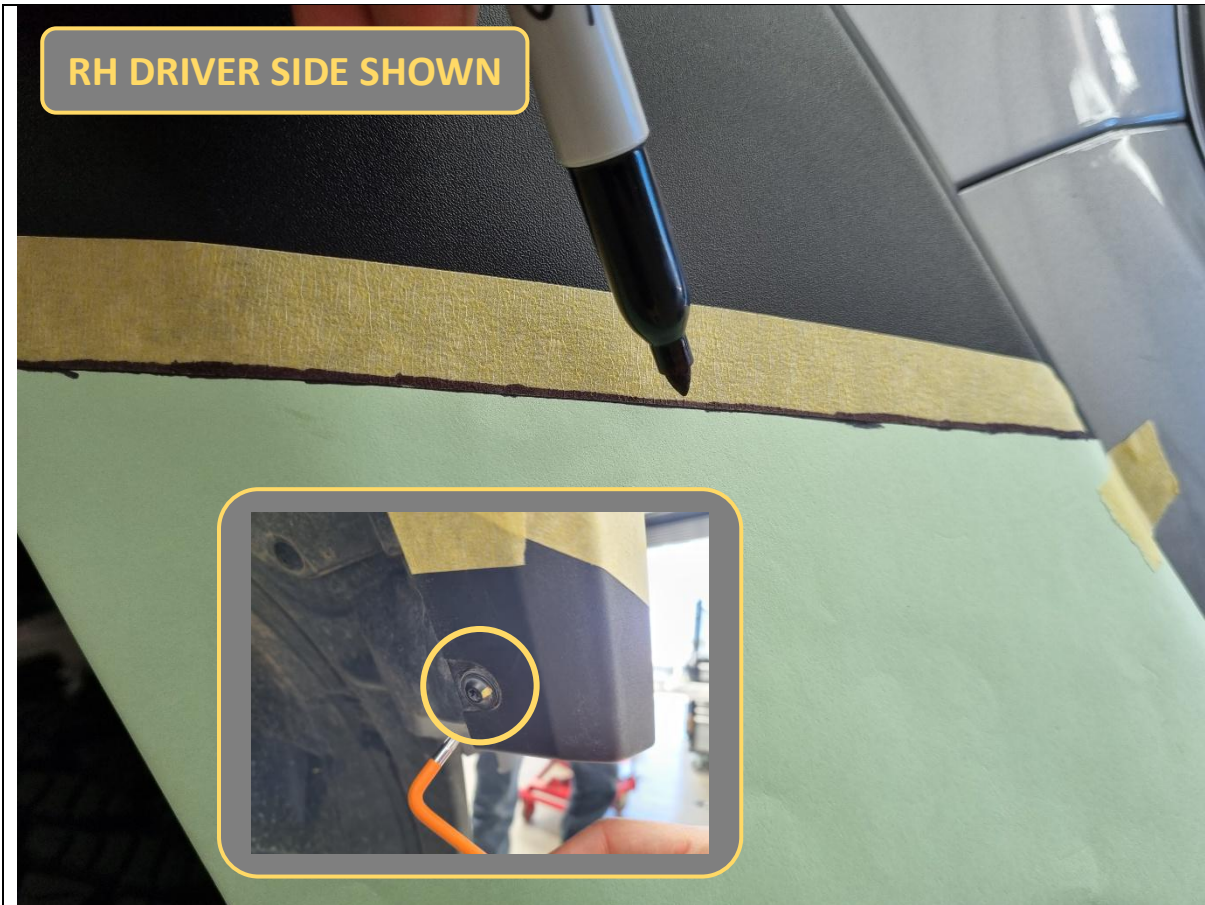

**RH DRIVER SIDE SHOWN**

32. Mark out the cut line with a marker pen, then remove the paper template.
33. Remove and discard 1x T25 Torx screw holding the end of the flare.

**TOOLS REQUIRED**

- Marker pen
- T25 Torx bit

**FASTENERS**

- 1x T25 Torx screw
- Discard



- 34. Gently pull out and unclip the end of the flare so it is away from the bumper fascia in preparation for cutting.
- 35. Stuff a workshop rag in between to keep the flare off the bumper fascia.

**TOOLS REQUIRED**

Workshop rag

**FASTENERS**

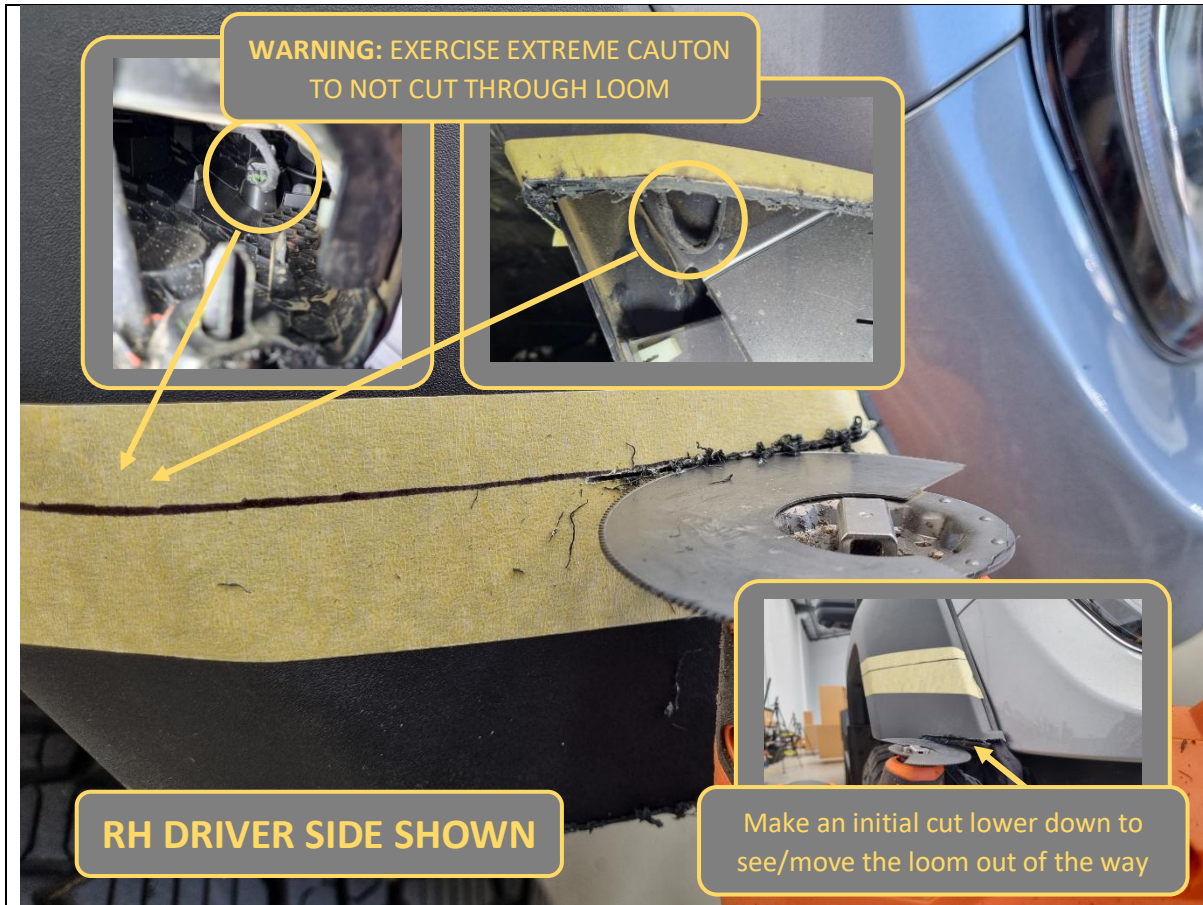

|  |  |
|--|--|
| <p>36. Time to cut the flare.</p> <p>Note that there is a wire loom for the side repeater lamp on the back of the flare that is extremely close to the flare cut line.</p>   | <p><b>TOOLS REQUIRED</b></p> <p>Multi-tool<br/>or<br/>Similar cutting tool</p> <p>Safety glasses</p> |
| <p>37. Start by making an initial cut at least 30mm below the marked cut line (or cut the bottom cap off).</p> <p>38. Once you have visible access from below, move/reposition the loom so it is well clear of the flare cut line.</p> <p>39. Now carefully cut the flare along the marked cut line.</p> | <p><b>FASTENERS</b></p>  |



40. Discard the lower cut off portion of the flare and remove masking tape.

41. Deburr the cut edge.

**TOOLS REQUIRED**

Deburring tool

**FASTENERS**

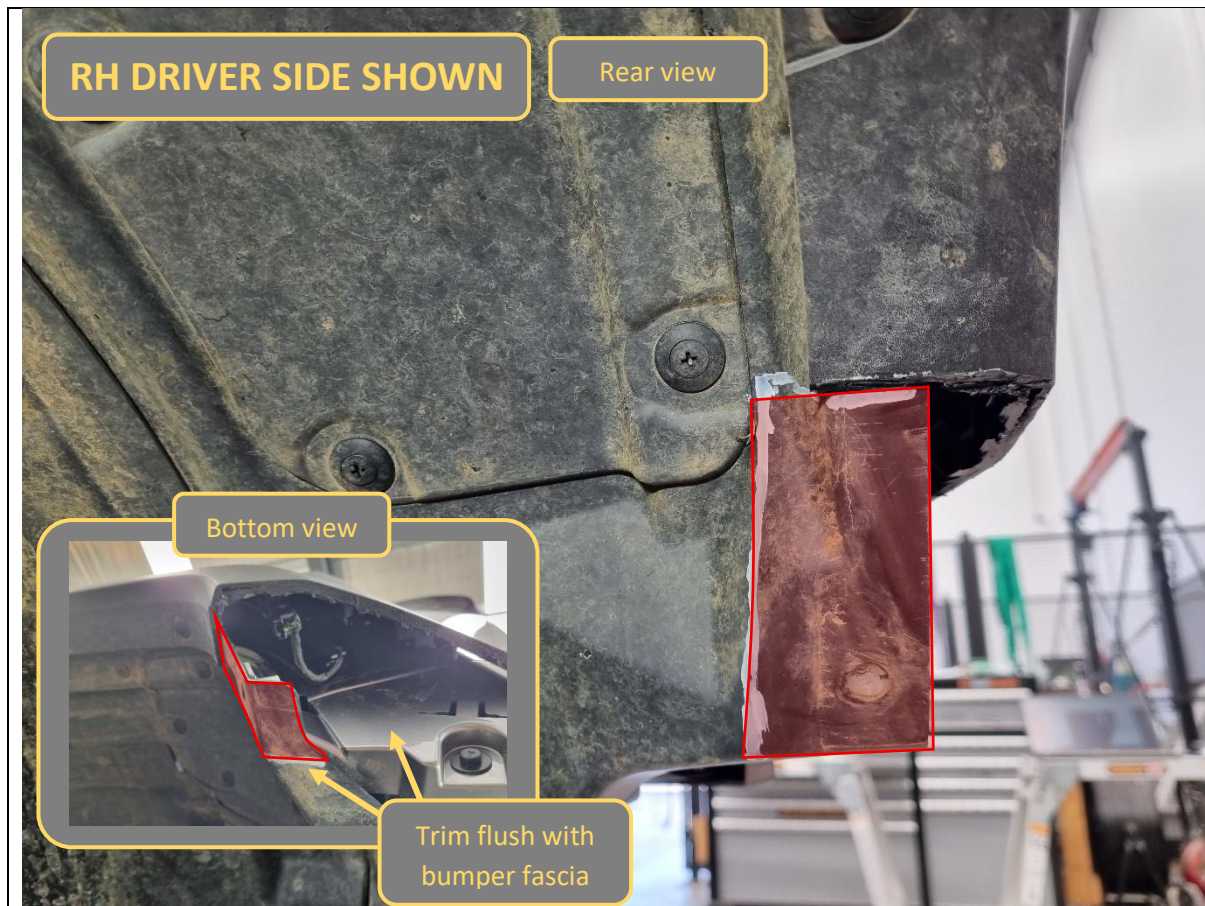

42. The wheel arch liner also needs a trim. Cut off the area highlighted.

When looking from the rear/below, this section of the wheel arch liner needs to be cut flush with the plastic bumper fascia.

Also cut off an extra section at the top, so you can physically reach in and fit a nut behind the flare later.

43. Deburr the trimmed edges.

**TOOLS REQUIRED**

Multi-tool  
or  
Similar cutting tool

Safety glasses

Deburring tool

**FASTENERS**



44. Also cut off the mounting block on the bumper fascia.

45. Deburr the cut edges.

**TOOLS REQUIRED**

Multi-tool  
or  
Similar cutting tool

Safety glasses

Deburring tool

**FASTENERS**



46. Remove the 10mm hex screw holding the bumper fascia. Do not discard.

**TOOLS REQUIRED**

10mm socket/spanner

**FASTENERS**

1x factory 10mm hex screw

Retain



47. Fit the flare endcap onto the vehicle and secure to the bumper fascia with the 10mm hex screw removed in the previous step.

Ensure the flare endcap is pressed firmly up and against the flare so that there is minimal gap.

**TOOLS REQUIRED**

10mm socket/spanner

**FASTENERS**

1x factory 10mm hex screw

Retained from Step 43



48. Locate the hole on the back of the flare endcap and use it as a guide to drill a 5mm hole into the flare.

Ensure the flare endcap is pressed snug up against the flare before drilling.

49. Secure the back of the endcap to the flare with 1x M6x16 black self tapping screw.

50. Repeat the entire flare procedure for the other side of the car.

**TOOLS REQUIRED**

- 5mm drill bit
- Electric drill
- Safety glasses

Phillips head screwdriver

**FASTENERS**

1x M6x16 self tapping screw

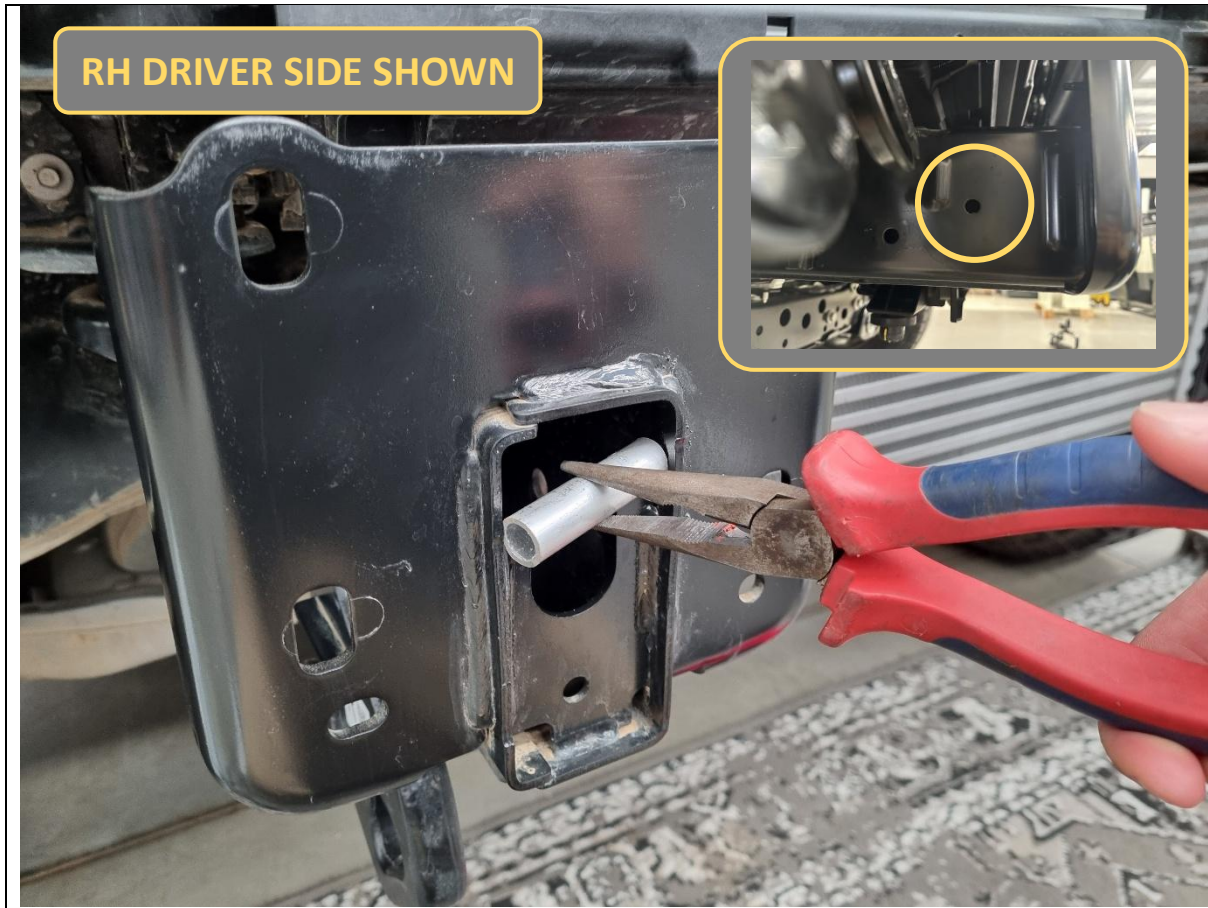

51. Use a pair of pliers to position the T-0174 crush tube inside the front end of the chassis rail. Align it with the through hole on the sides of the chassis.

**TOOLS REQUIRED**

Pliers

**FASTENERS**

T-0174 crush tube

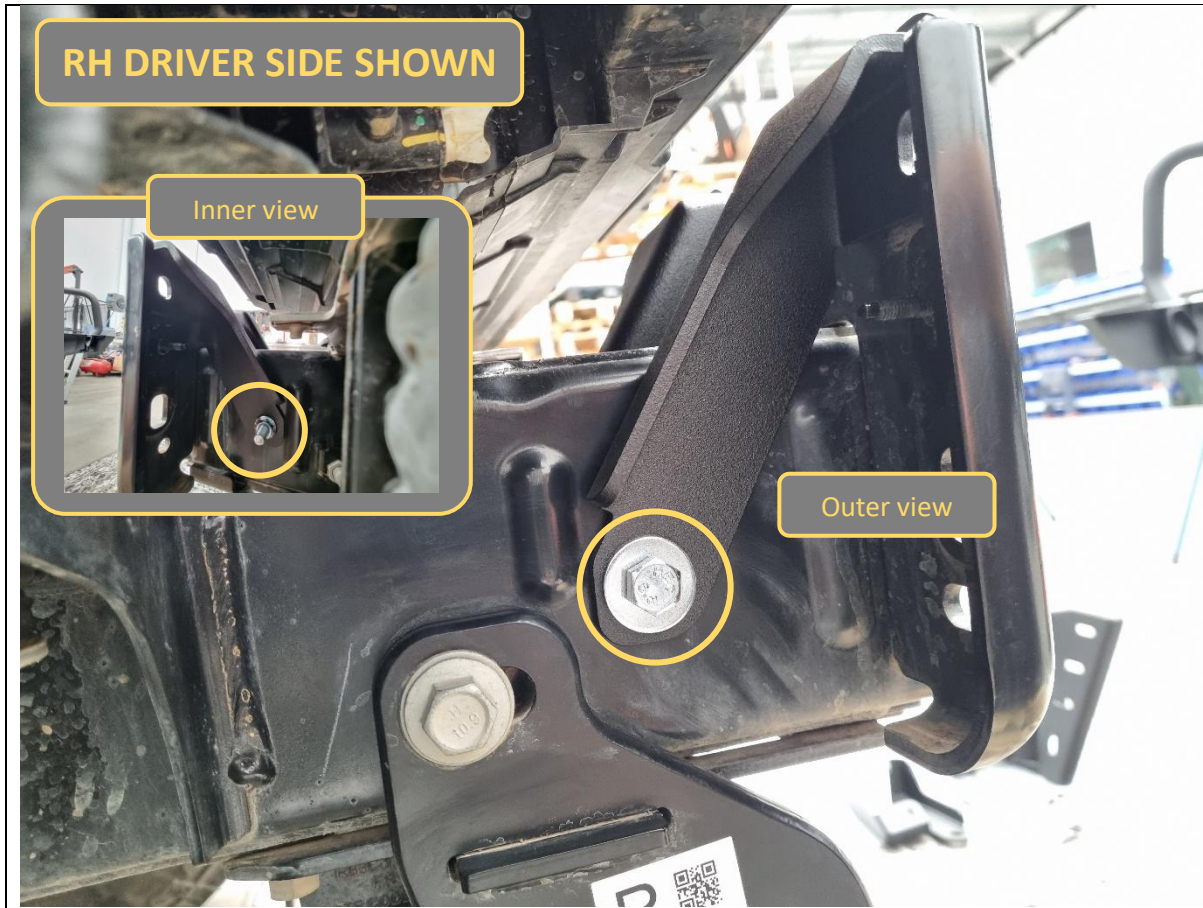

- 52. Fit the pair of chassis braces to the outer and inner faces of the chassis rail.
- 53. Loosely secure to the chassis with 1x M10x100 hex bolt, heavy duty washer and flange nut.

**TOOLS REQUIRED**

**FASTENERS**

- 1x M10x100 hex bolt
- 1x M10 heavy duty washer
- 1x M10 flange nut

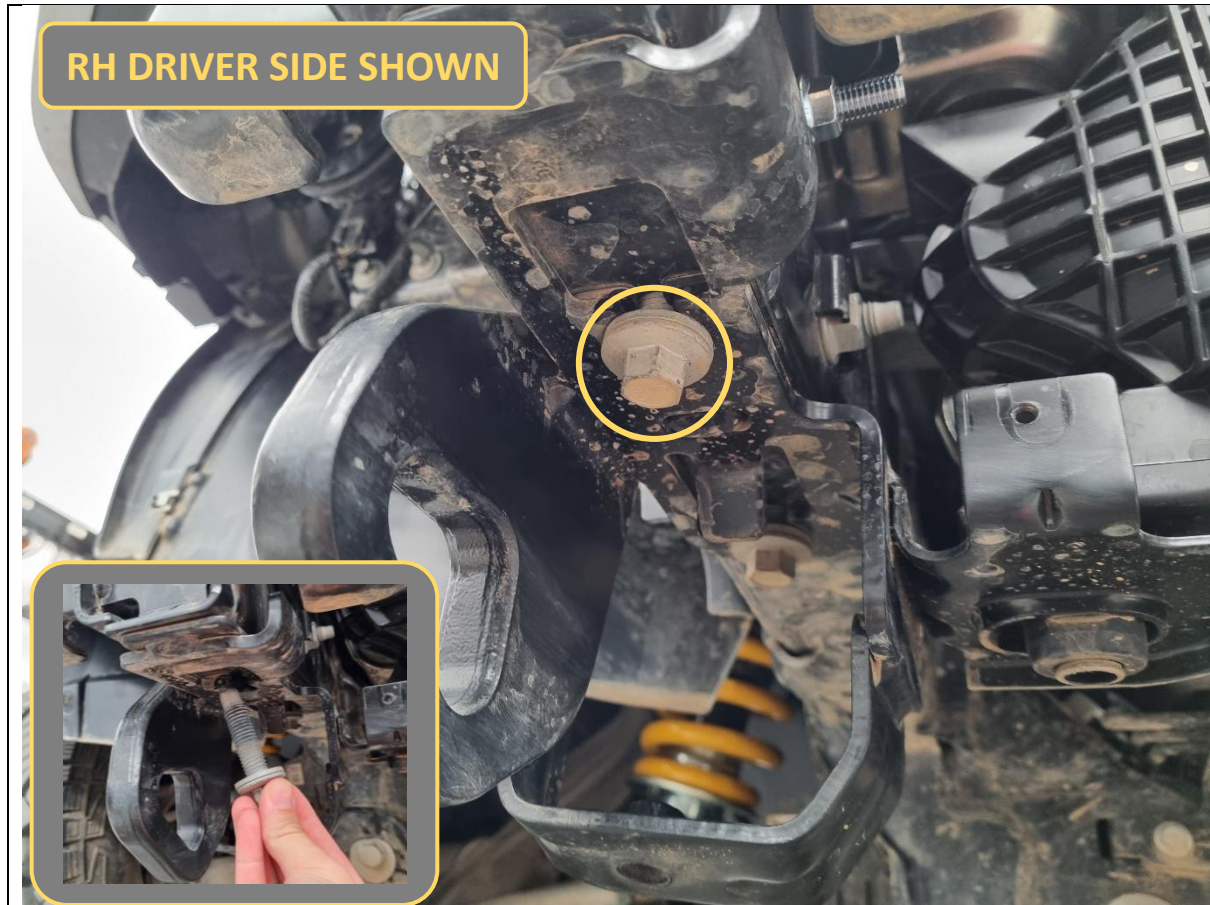

54. On the underside, remove the front 15mm hex bolt holding the factory recovery point.

55. Retain for re-use.

**TOOLS REQUIRED**

15mm socket/spanner

**FASTENERS**

1x factory 15mm hex bolt

Retain



- 56. Pre-position 2x M12x40 hex bolts and heavy duty washers through the middle pair of holes on the impact assembly.
- 57. Pre-position 2x M10x40 hex bolts and heavy duty washers through the bottom pair of holes on the impact assembly.
- 58. On the back, pre-position 2x P-0551 spacer plates to each group of M10/M12 bolts.

**TOOLS REQUIRED**

**FASTENERS**

2x M10x40 hex bolt  
2x M10 heavy duty washer

2x M12x40 hex bolt  
2x M12 heavy duty washer

4x P-0551 spacer plate



**RH DRIVER SIDE SHOWN**

- 59. Fit the impact assembly onto the end of the chassis horn.
- 60. Loosely secure with 2x M10 flange nuts and 2x M12 flange nuts on the rear.

**TOOLS REQUIRED**

**FASTENERS**

- 2x M10 flange nut
- 2x M12 flange nut



61. Loosely secure the top of the impact assembly to each chassis brace with 1x M12x30 hex bolt, heavy duty washer and flange nut.

**TOOLS REQUIRED**

**FASTENERS**

- 2x M12x30 hex bolt
- 2x M12 heavy duty washer
- 2x M12 flange nut

**RH DRIVER SIDE SHOWN**



- 62. Re-fit the tow point bolt to the bottom of the impact assembly and chassis.
- 63. Snug up the bolt so that the impact assembly is pressed up against the chassis, but still loose enough to adjust left/right.
- 64. Repeat procedure for fitment of impact assembly and chassis brace on other side of chassis.

**TOOLS REQUIRED**

15mm socket/spanner

**FASTENERS**

1x factory 15mm hex bolt

Retained from Step 54

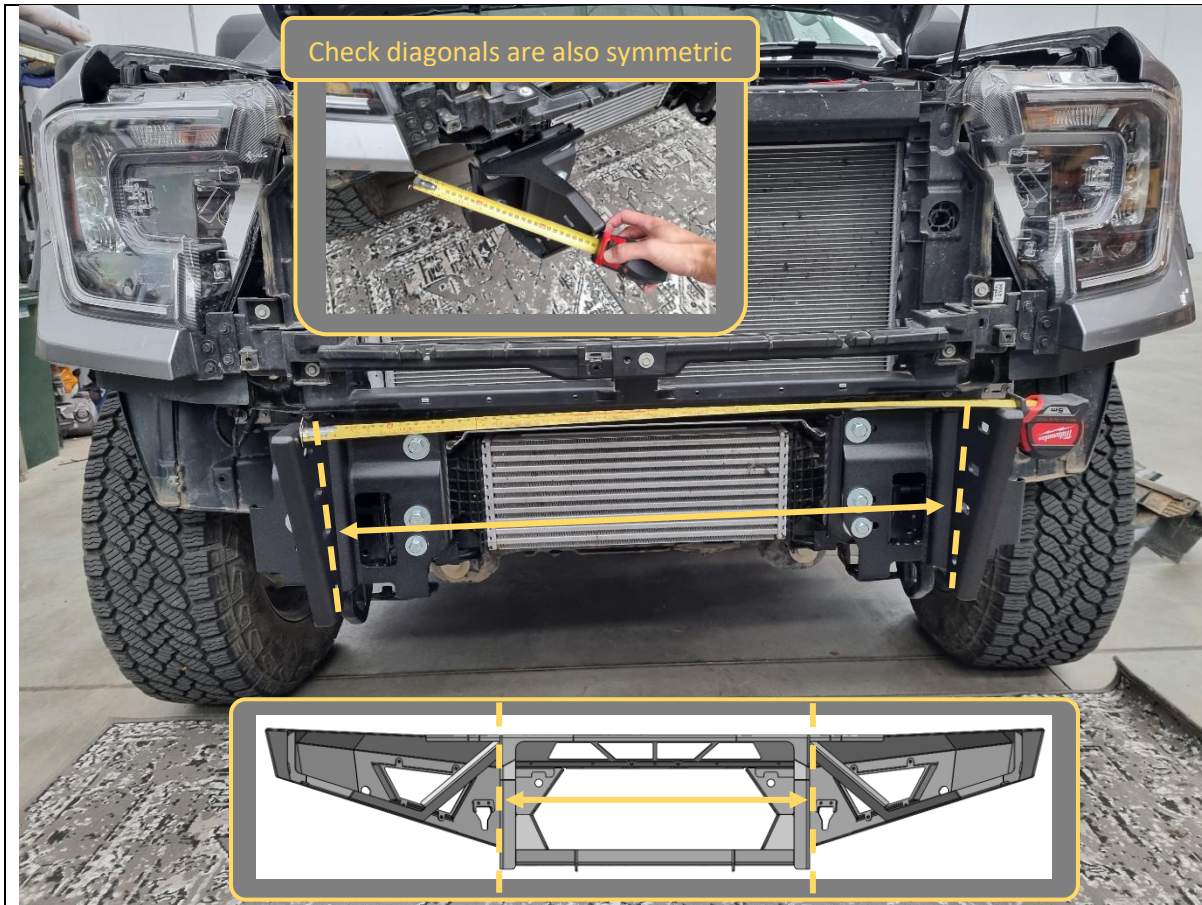

65. Measure the distance between the outside faces of the uprights on the bull bar using a tape measure. Write the distance below for reference if required:

Bar upright width = \_\_\_\_\_ mm

66. Adjust the impact assemblies by sliding left/right on the slots, such that the distance between the inner mounting faces of the impact assemblies are 2-5mm more than the bull bar distance.

67. Ensure the mount faces are vertically upright and symmetric left/right on the vehicle.

Measure to the corners of the headlights or similar to check, rather than using the chassis as reference.

This is because the body of the vehicle may not necessarily be mounted centrally on the chassis.

**TOOLS REQUIRED**

Tape measure

**FASTENERS**



68. Once happy with alignment, tighten all bolts holding impact assemblies and chassis braces in the following order:
- a. Front M12 bolts (torque to 100Nm)
  - b. Front M10 bolts (torque to 57Nm)
  - c. Chassis brace side M10 bolts (torque to 57Nm)
  - d. Bottom recovery point bolts (torque to 164Nm)

69. Re-check the distance and re-adjust if required.

**TOOLS REQUIRED**

15mm socket/spanner  
16/17mm socket/spanner  
18/19mm socket spanner

Torque wrench

**FASTENERS**

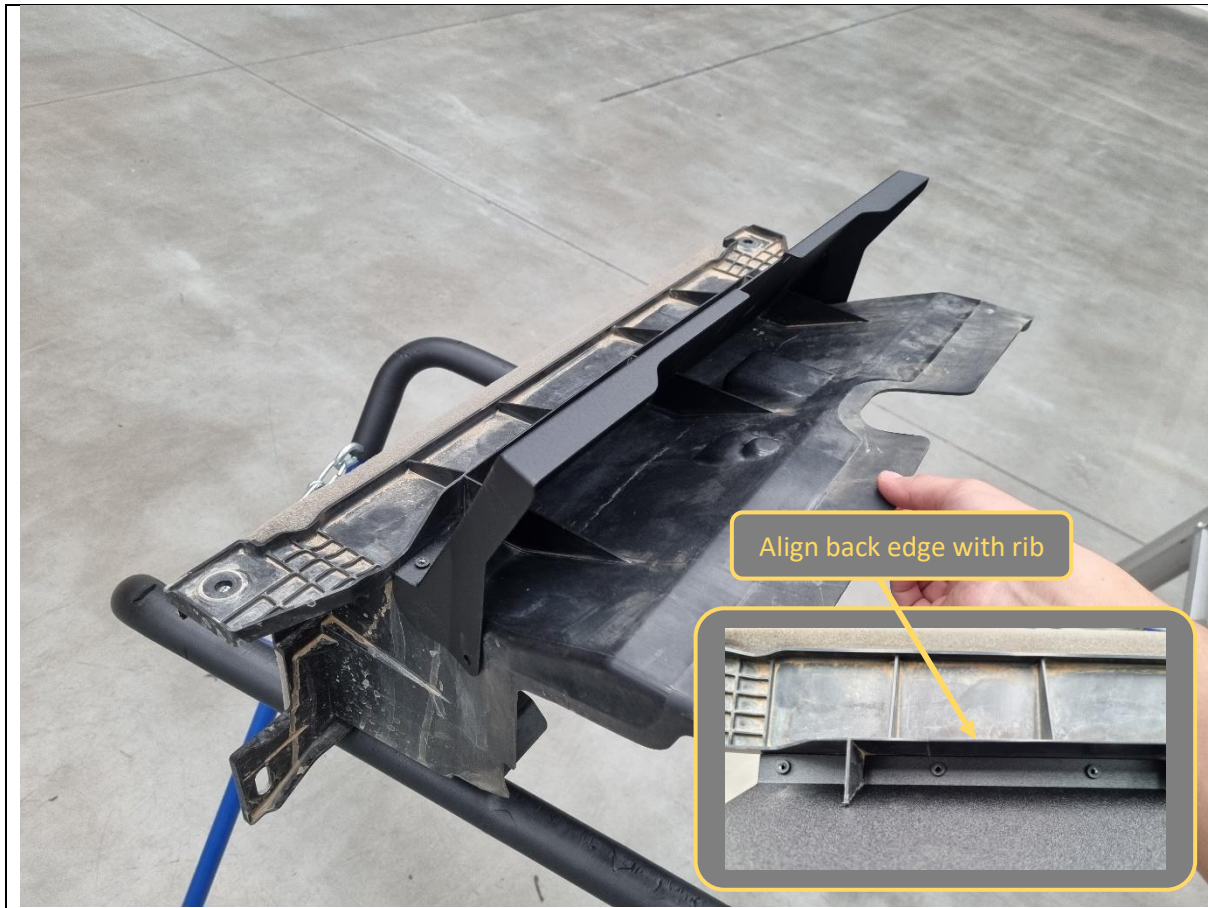

- 70. Dry test fit the B-1834 intercooler air guide onto top of the factory intercooler shroud removed earlier.
- 71. Align the air guide so the back edge is flush on the plastic rib.

**TOOLS REQUIRED**

**FASTENERS**

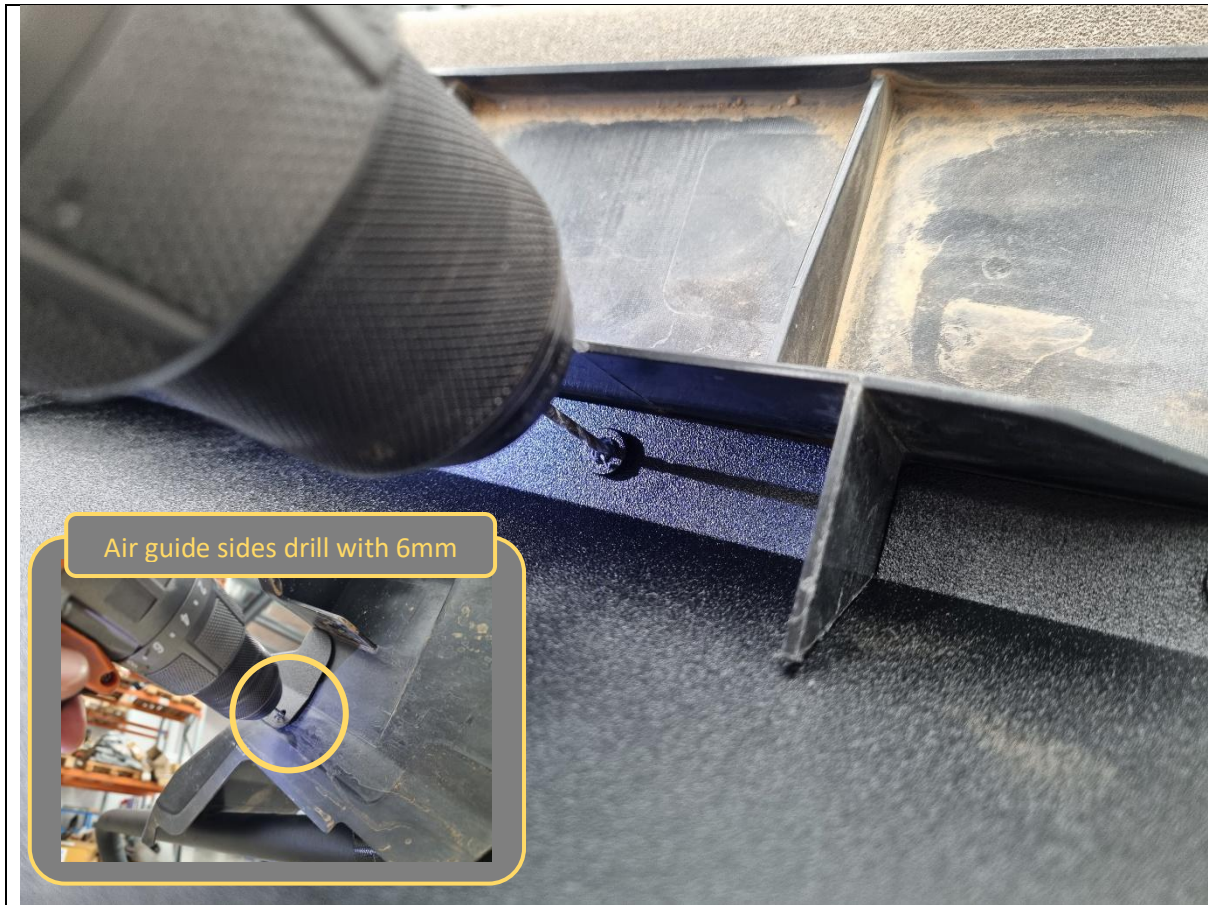

72. Use 2mm + 6mm drill bits and the air guide holes/nutserts as a guide to drill small pilot holes around the intercooler shroud.

There are 6x holes on top (drill 2mm), and 1x on each side (drill 6mm). So 8x pilot holes in total.

**TOOLS REQUIRED**

2mm drill bit  
6mm drill bit  
Electric drill

Safety glasses

**FASTENERS**

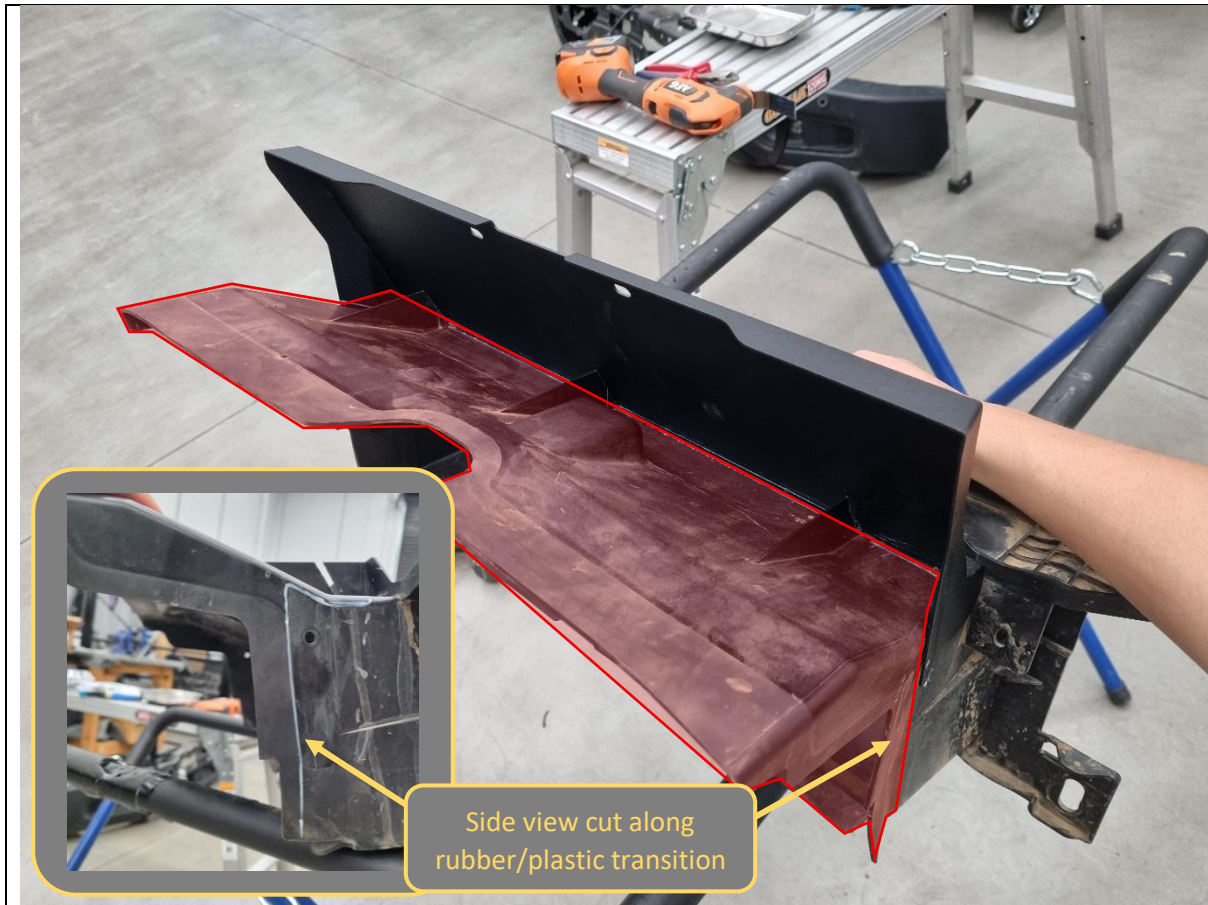

73. Use a marker pen and the air guide as reference and mark out the front section of the intercooler shroud which will need to be trimmed.

**TOOLS REQUIRED**

Marker pen

**FASTENERS**

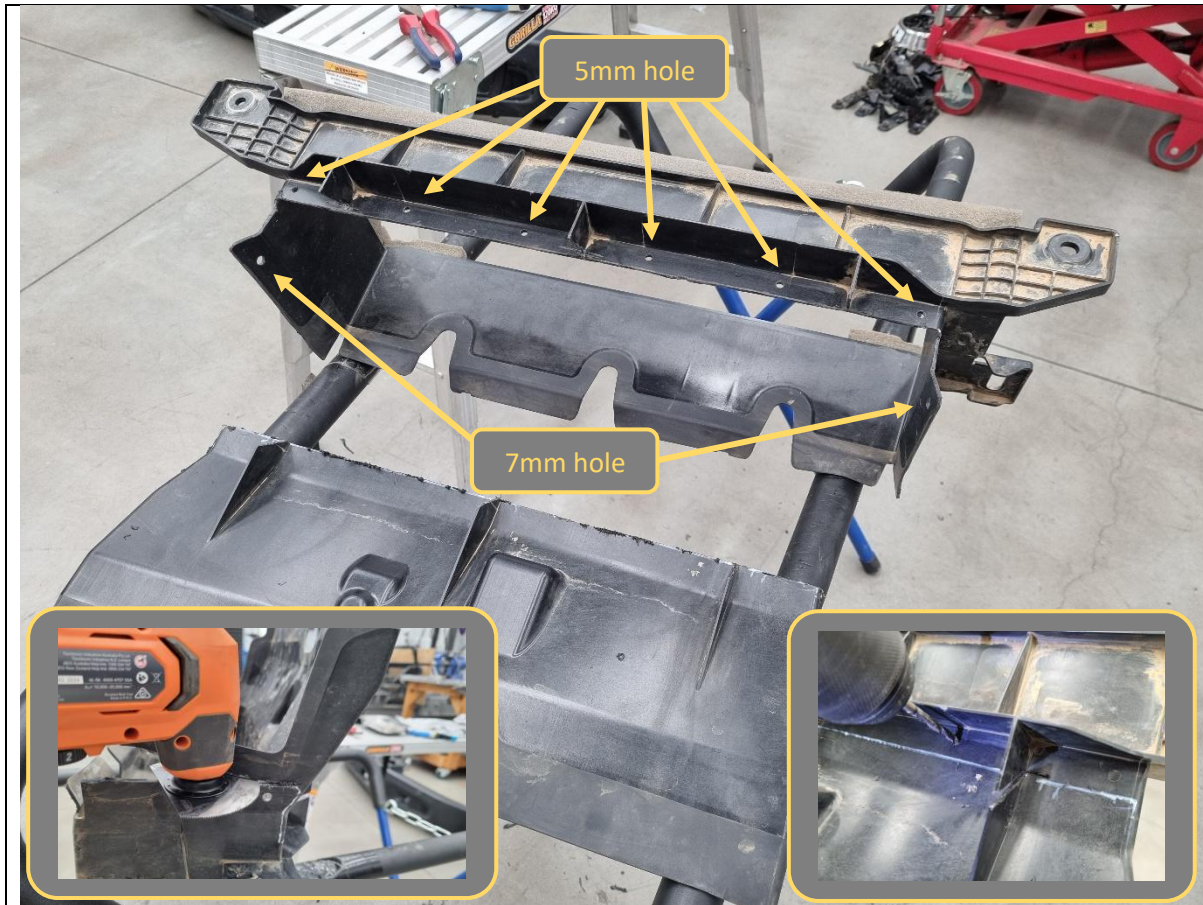

- 74. Remove the air guide from the intercooler shroud.
- 75. Use the pilot holes as a guide and drill out the 6x top holes to 5mm diameter.
- 76. Use the pilot holes as a guide and drill out the 2x side holes to 7mm diameter.
- 77. Cut the intercooler shroud along the marked cut line, then deburr sharp edges.

**TOOLS REQUIRED**

5mm drill bit  
7mm drill bit  
Electric drill

Multi-tool  
or  
Similar cutting tool

Safety glasses

Deburring tool

**FASTENERS**



78. Re-fit the modified intercooler shroud to the vehicle, re-using the factory 8mm hex bolts removed earlier.

**TOOLS REQUIRED**

8mm socket/spanner

**FASTENERS**

4x factory 8mm hex bolt

Retained from Step 20

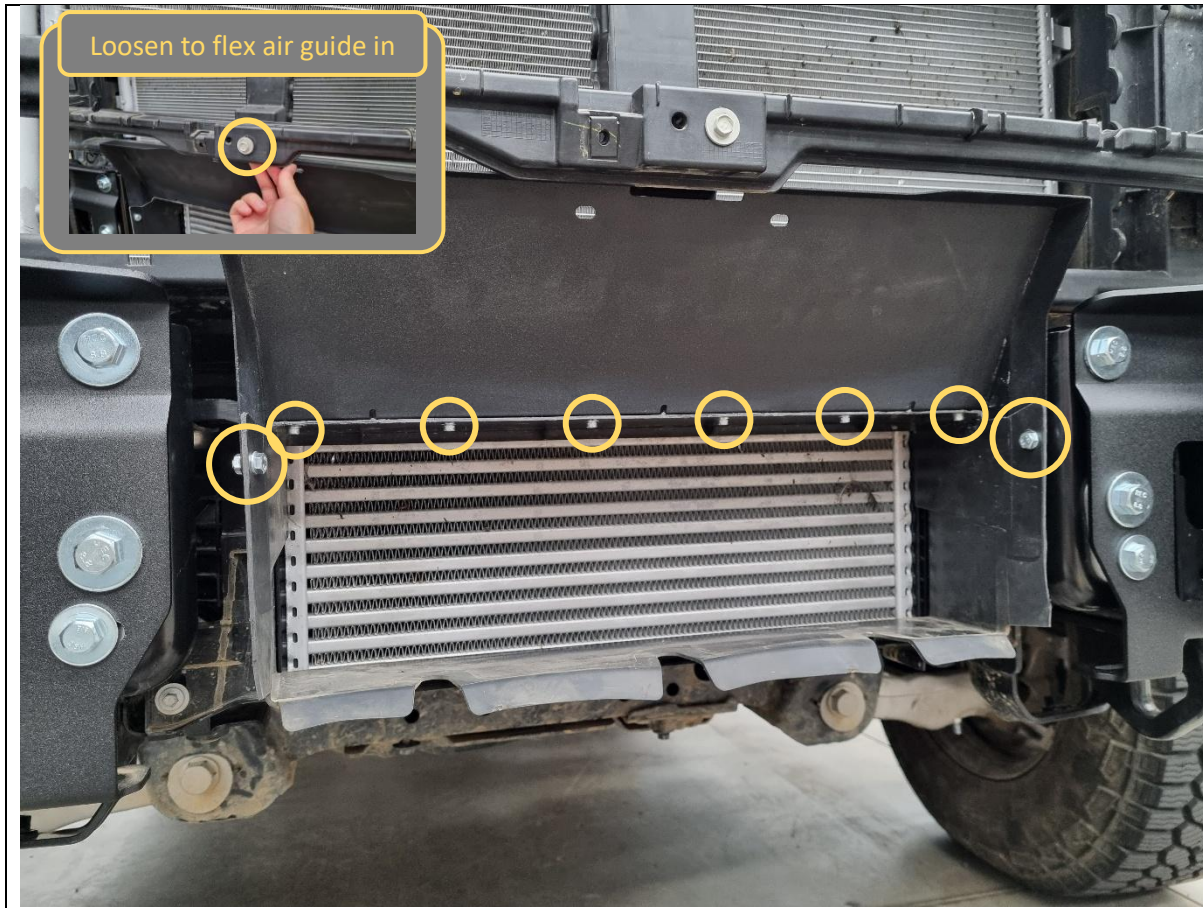

79. Fit the air guide to the modified intercooler shroud.

Note: You may need to temporarily remove/loosen the 10mm hex bolt up top and pull the grille support structure outwards to be able to flex the air guide into position.

80. Secure the air guide to the intercooler shroud with 6x M4x10 hex bolts and washers along the top edge, and 2x M6x12 hex bolts, washers and flange nuts on the sides.

**TOOLS REQUIRED**

7mm socket/spanner  
10mm socket/spanner

**FASTENERS**

6x M4x10 hex bolt  
6x M4 flat washer

2x M6x12 hex bolt  
2x M6 flat washer  
2x M6 flange nut



81. Position the B-1835 air guide centre support bracket on top and clip into the plastic structure with 1x plastic push clip retained from removing the bumper trim.

**TOOLS REQUIRED**

**FASTENERS**

1x plastic push clip  
Retained from Step 3

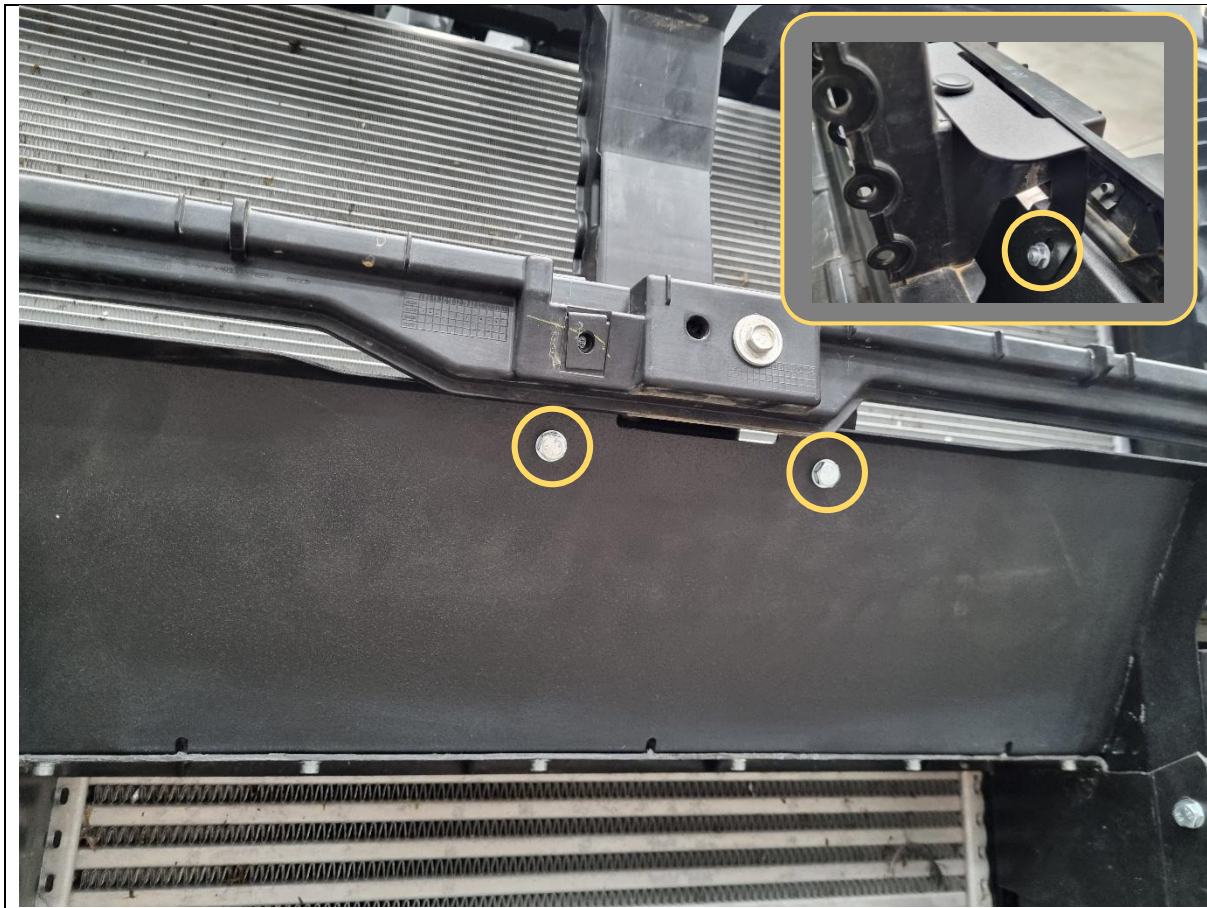

82. Secure the air guide to the support bracket with 2x M6x12 hex bolts, washers and flange nuts.

**TOOLS REQUIRED**

10mm socket/spanner

**FASTENERS**

2x M6x12 hex bolt  
2x M6 flat washer  
2x M6 flange nut

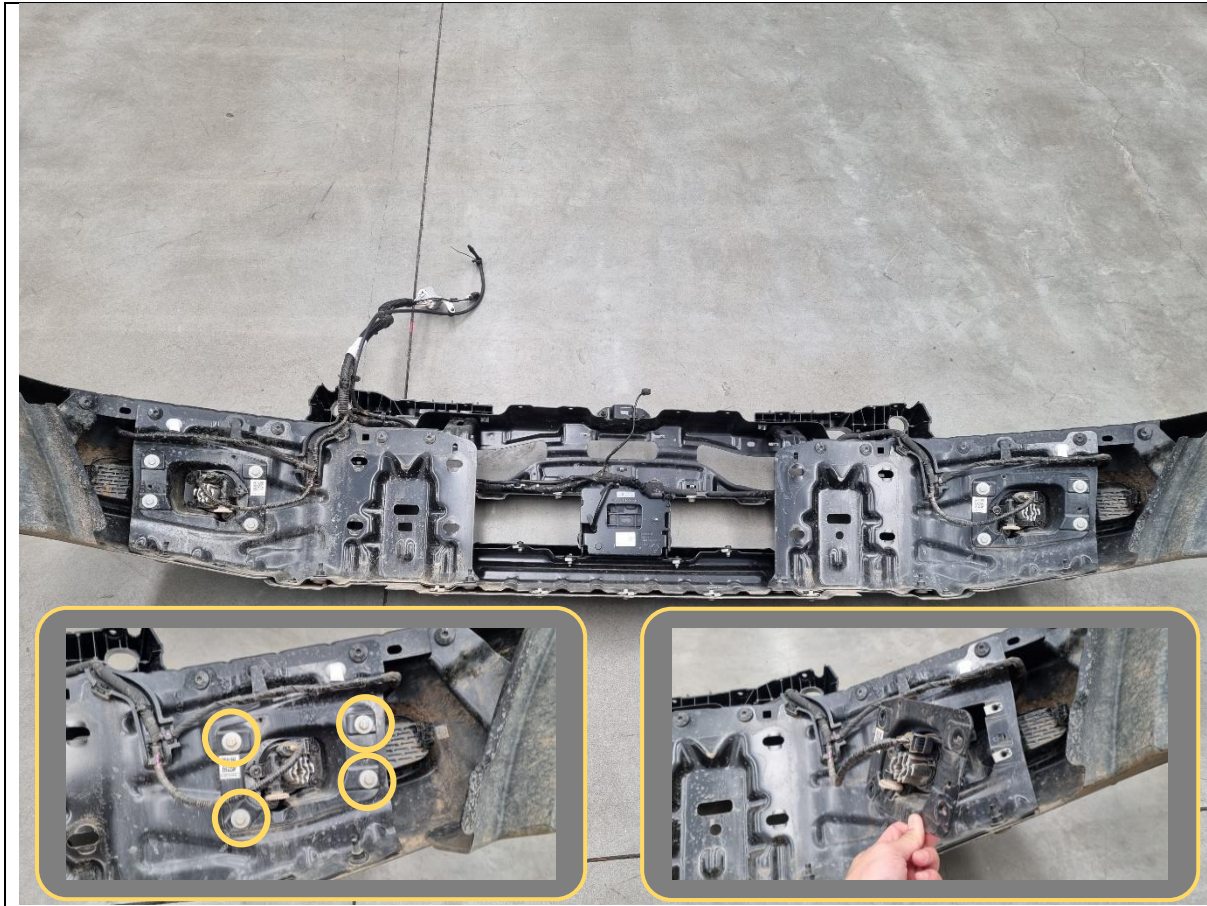

83. Time to strip the bumper. Remove 4x 10mm hex bolts holding each fog light housing to the inner bumper skin.

**TOOLS REQUIRED**

10mm socket/spanner

**FASTENERS**

8x factory 10mm hex bolt

Discard

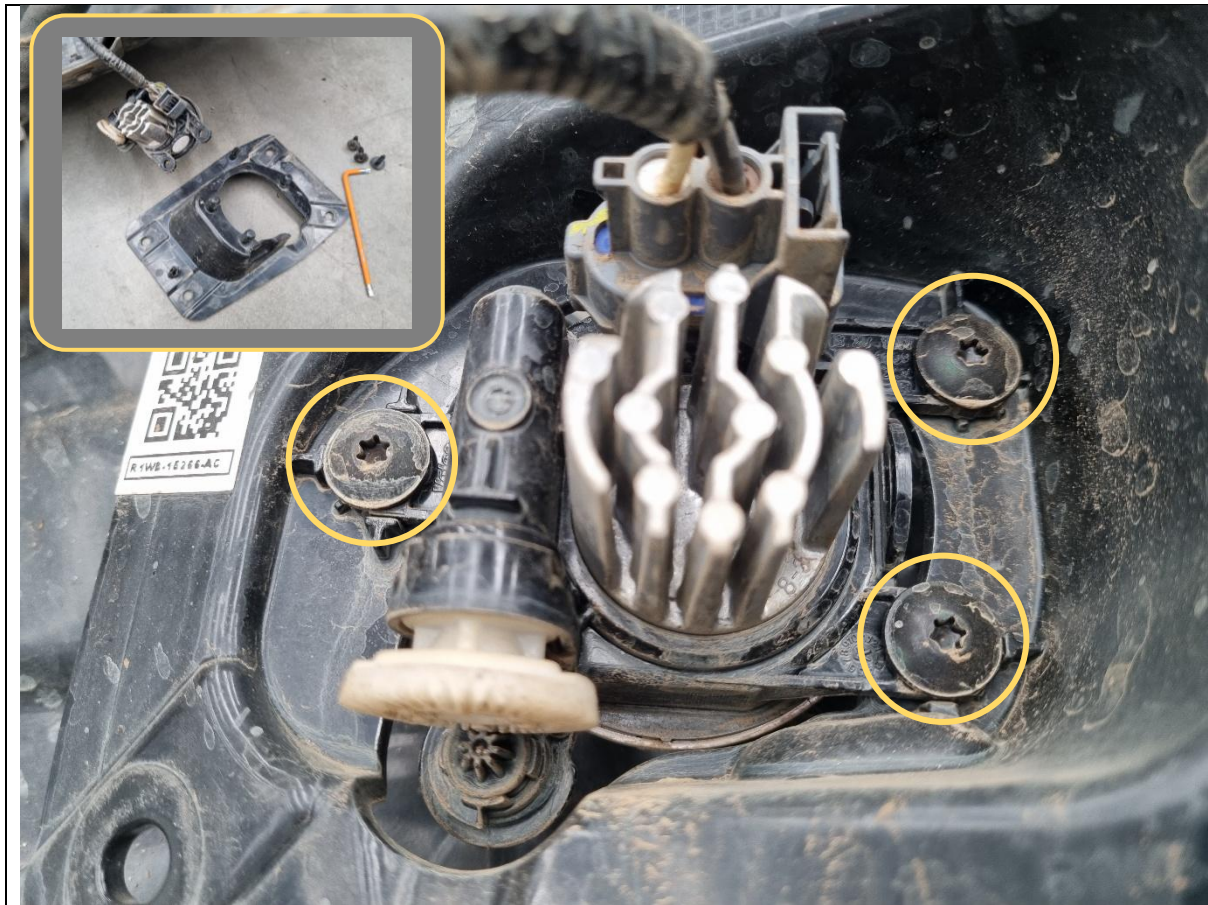

84. Remove and discard 3x T25 Torx screws holding each fog light to its plastic housing.

**TOOLS REQUIRED**

T25 Torx bit

**FASTENERS**

6x T25 Torx screw

Discard



- 85. Reach through the fog light opening in the bumper and locate the outer parking sensor on each side.
- 86. Spread the plastic locking tabs apart and unclip both parking sensors.

**TOOLS REQUIRED**

**FASTENERS**



87. Locate the camera on top of the bumper and remove 2x 10mm hex bolts holding the camera clamp bracket to the mounting bracket.

88. Unclip the camera and washer from the front bracket.

**TOOLS REQUIRED**

10mm socket/spanner

**FASTENERS**

2x factory 10mm hex bolt

Discard



89. Separate the washer nozzle from the camera body.

**TOOLS REQUIRED**

**FASTENERS**

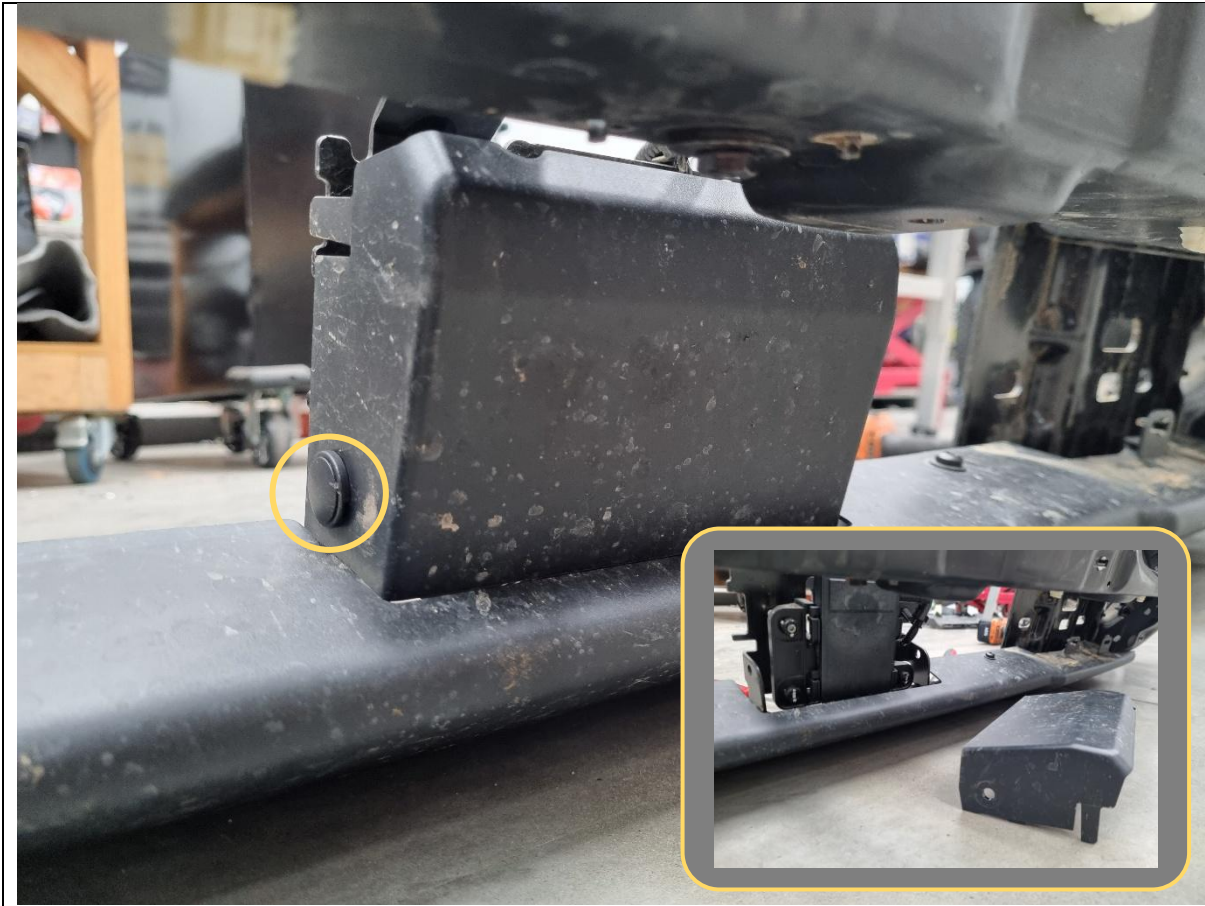

90. Remove 2x plastic push clips holding on the plastic radar cover. Discard parts.

**TOOLS REQUIRED**

Trim tool  
or  
Flat blade screwdriver

**FASTENERS**

2x plastic push clips

Discard

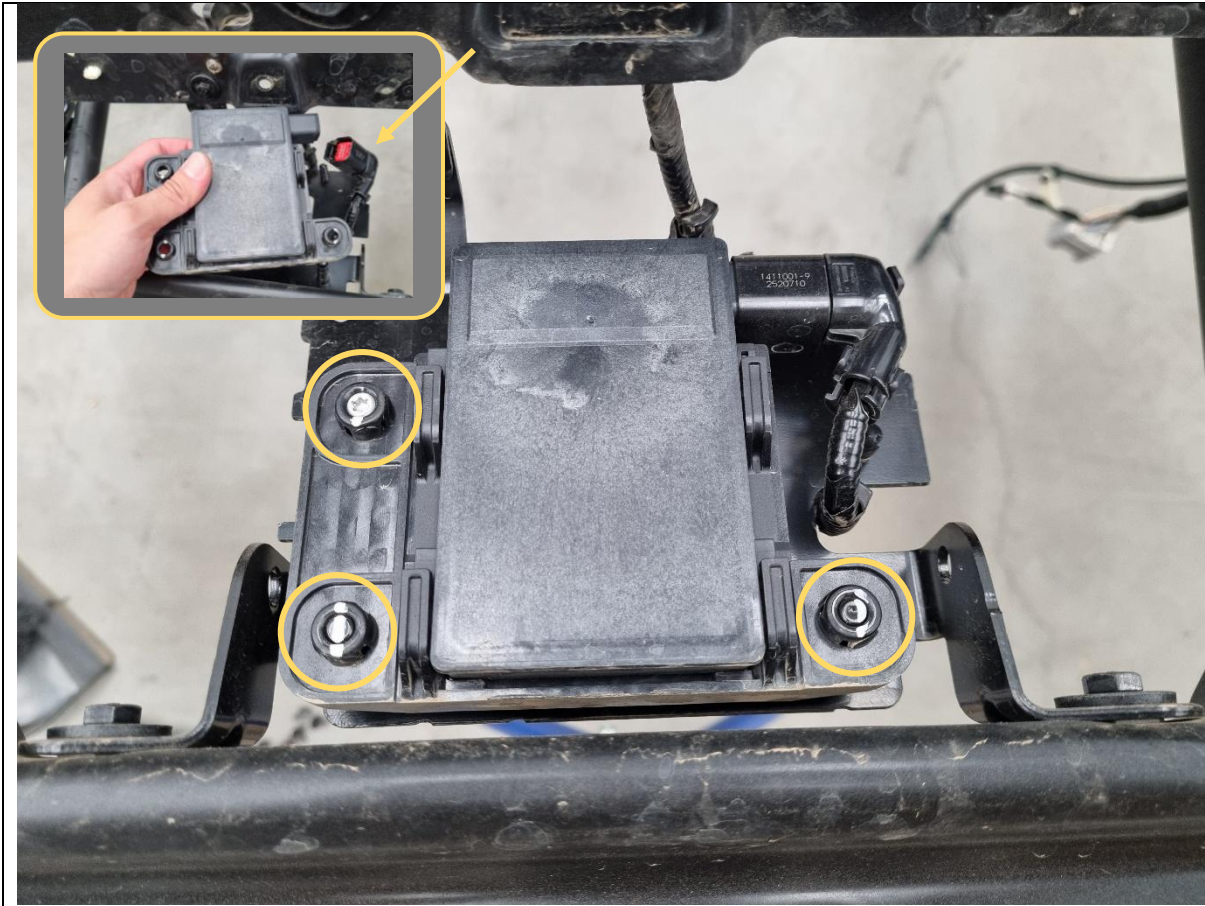

91. Carefully pull outwards and unclip the radar from the ball point mounts.
92. Disconnect the radar at the plug and set it aside in a safe place.

**WARNING**

Take extra care to not drop or impact the radar.

**TOOLS REQUIRED**

**FASTENERS**

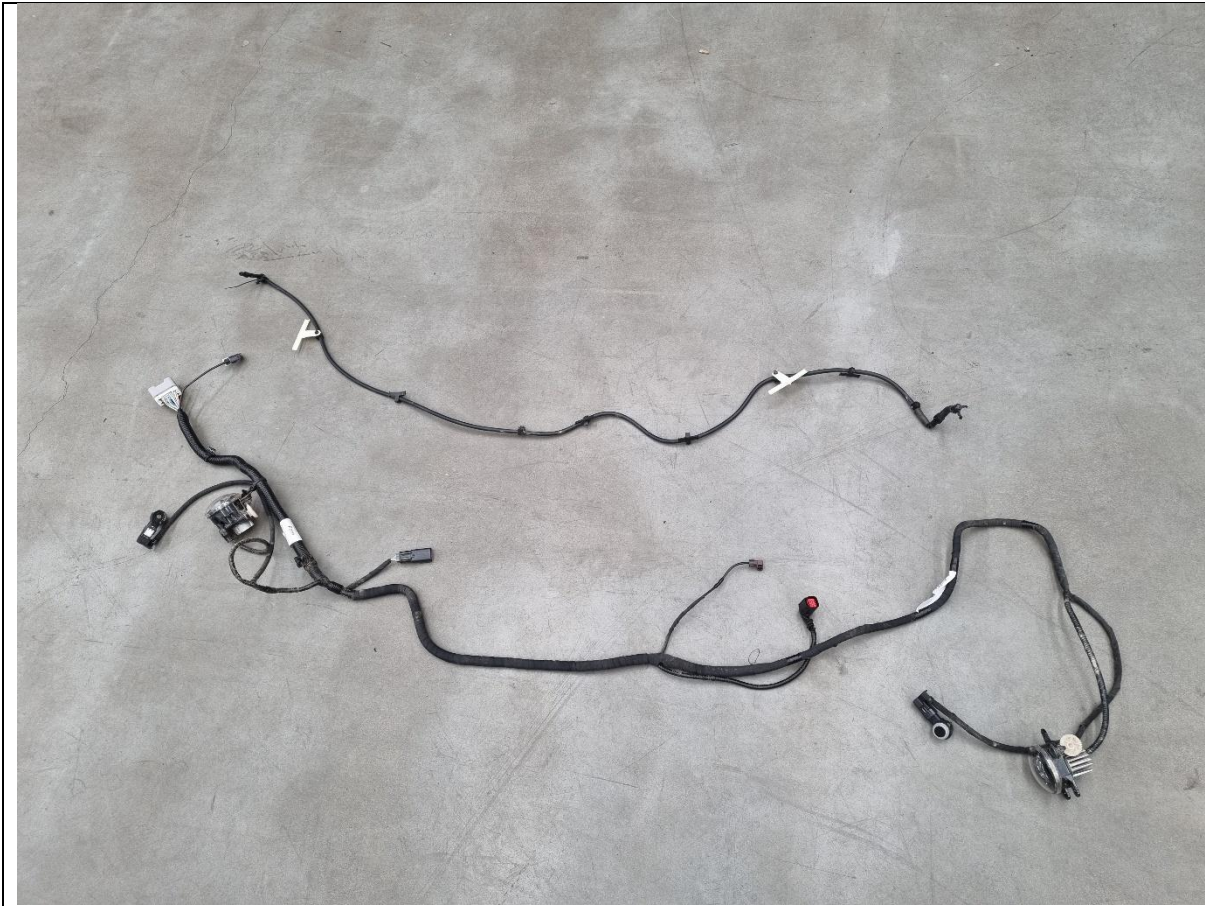

- 93. Unclip the loom from the bumper.
- 94. Separate the washer hose from the main bumper harness.

**TOOLS REQUIRED**

Trim tool  
or  
Flat blade screwdriver  
or  
Side cutters

**FASTENERS**



95. Fit the mesh infill plate from inside the bull bar and secure with 7x M6x12 black countersunk bolts and flange nuts.

**TOOLS REQUIRED**

4mm hex/Allen key

**FASTENERS**

7x M6x12 black countersunk  
7x M6 flange nut



96. Fit 10x M6 cage nuts into the rectangular slots in bottom of the bull bar wings (5x per side).

There should be two types of M6 cage nuts supplied. There are 10x cage nuts suited for thicker 3mm sheet metal, which are to be used here. The other 2x cage nuts are suited for thinner 2mm sheet metal and will be used later.

Use a small flat blade screwdriver to push the edge of the cage to engage with the slot to aid fitting.

**TOOLS REQUIRED**

Flat blade screwdriver

**FASTENERS**

10x M6 cage nuts  
(to suit 3mm sheet metal)



**RH DRIVER SIDE SHOWN**

97. Fit the wing meshes to the inside of each bull bar wing and secure each one with 4x M6x12 hex bolts and washers.

**TOOLS REQUIRED**

10mm socket/spanner

**FASTENERS**

8x M6x12 hex bolt  
8x M6 flat washer

**TORO BARS or PREDATOR BAR W/ROUND HOOP ONLY**

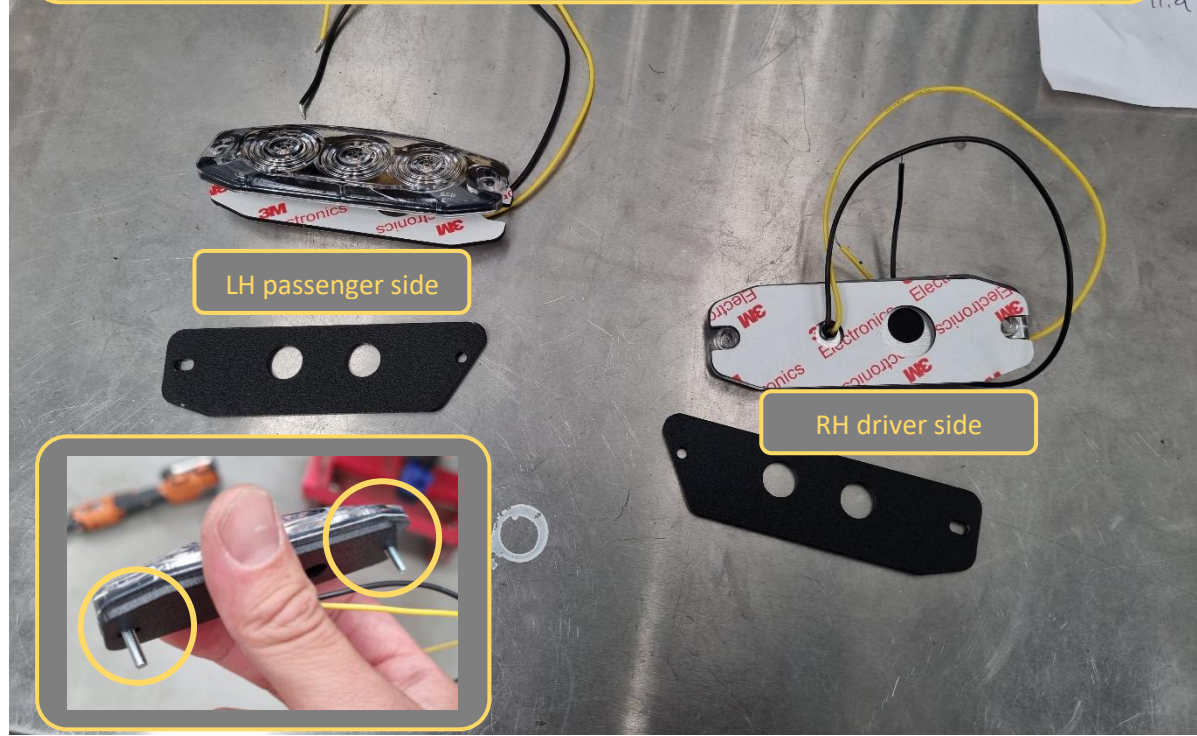

**All Toro bars require indicator repeaters to be installed.**

**Predator bars fitted with round hoop (TB-COM-PR-WD-RND-ASM0) also require indicator repeaters.**

98. Use the double-sided tape pad supplied with the indicator repeaters and affix to the P-0544 mounting plate.

Ensure the indicator repeaters are taped to opposite faces on the mounting plate (LH and RH need to be mirrored) like the image shown.

Also ensure the markings on the indicator repeaters are orientated up.

99. Pre-position 2x M3x16 pan head screws through the mounting holes of the indicator repeaters.

**TOOLS REQUIRED**

**FASTENERS**

4x M3x16 pan head screw

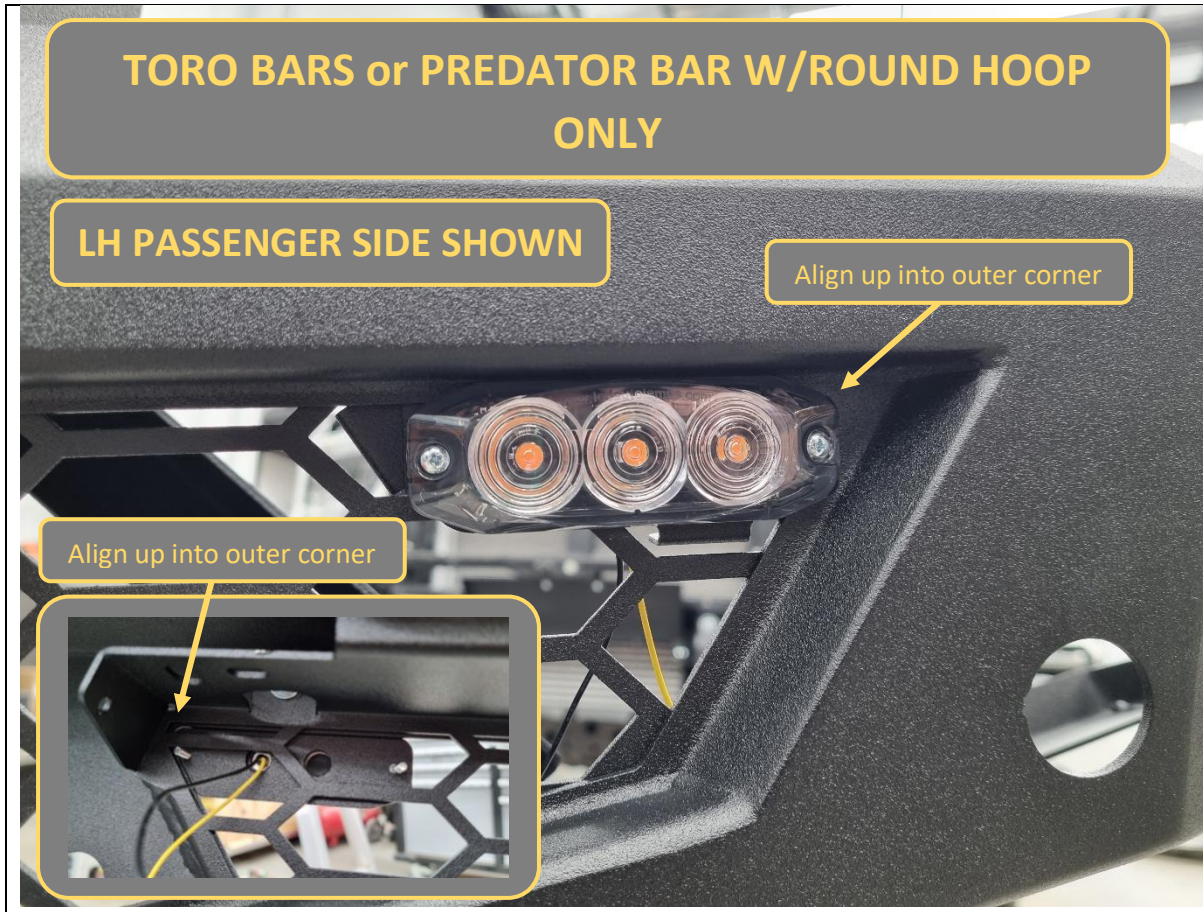

- 100. Peel off the film on the other side of the double-sided tape.
- 101. Fit the indicator repeater with mount plate to the outside of the wing mesh opening. Align the mount plate into the upper outer corner of the wing mesh opening.

**TOOLS REQUIRED**

**FASTENERS**



**TORO BARS or PREDATOR BAR W/ROUND HOOP ONLY**

**LH PASSENGER SIDE SHOWN**

|  |  |
|--|--|
| <p>102. Fit the B-1827 clamp bracket onto the rear and secure to the 2x M3x16 pan head screws with 2x flat washers and Nyloc nuts.</p> | <p><b>TOOLS REQUIRED</b></p> <p>PH1 Phillips head screwdriver<br/>5.5mm socket/spanner</p> |
|  | <p><b>FASTENERS</b></p> <p>2x M3 flat washer<br/>2x M3 Nyloc nut</p>                       |

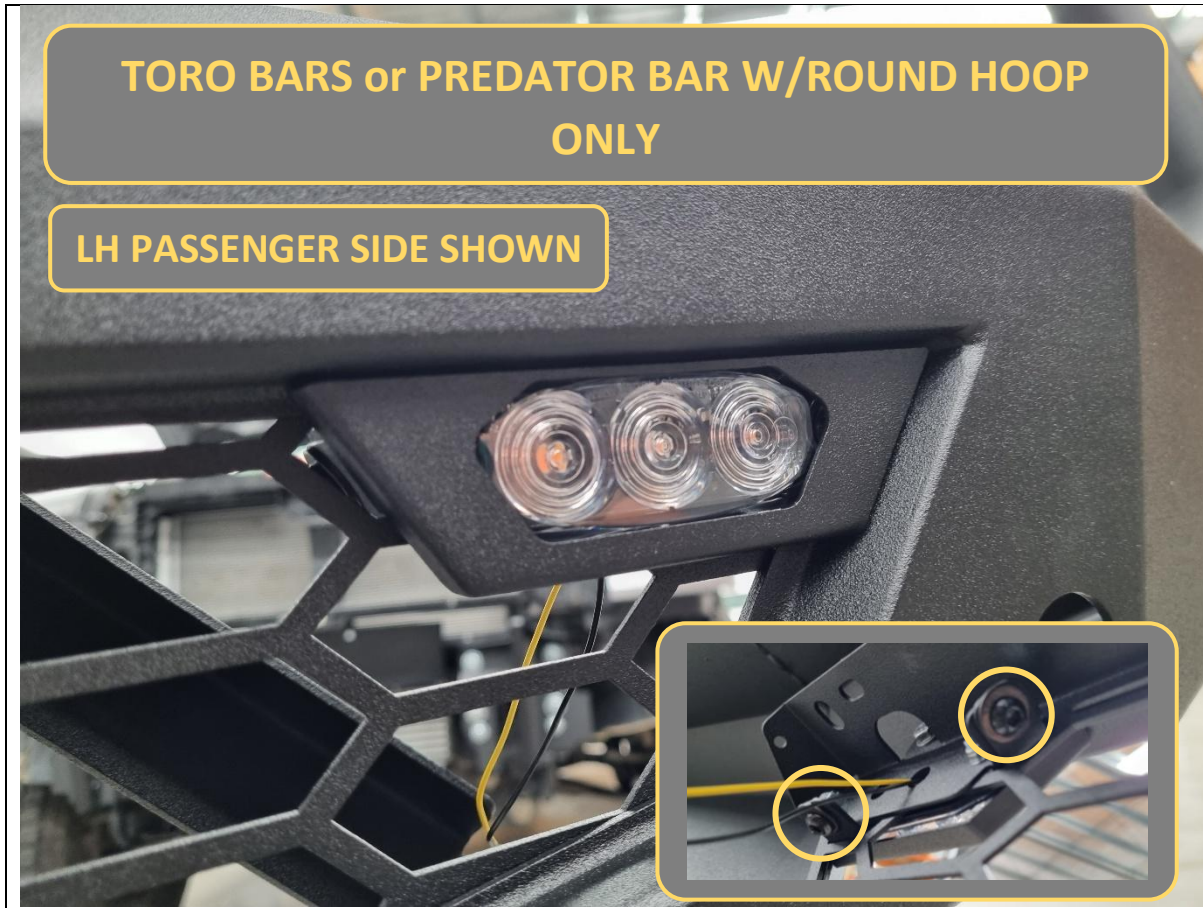

103. Fit the B-1828 housing from the outside and secure to the clamp bracket with 2x M6x12 black button head bolts, black washers and flange nuts.

**TOOLS REQUIRED**

4mm hex/Allen key

**FASTENERS**

2x M6x12 black button head  
2x M6 black washer  
2x M6 flange nut

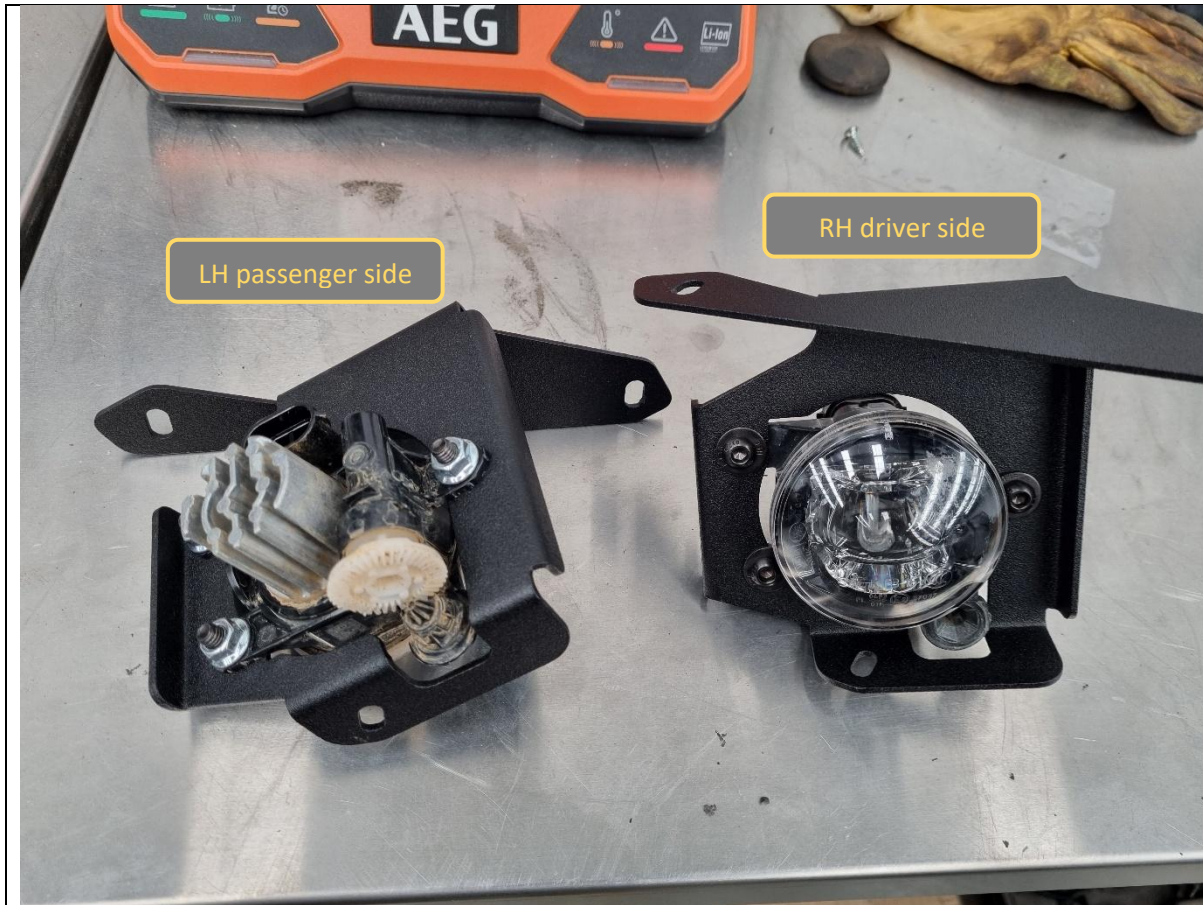

104. The Ford OE fog lights can be re-fitted to the bar. Fit the fog lights to the supplied B-1824 fog light brackets and secure with 3x M6x16 black button head bolts, black washers and flange nuts, each.

**TOOLS REQUIRED**

4mm hex/Allen key

**FASTENERS**

6x M6x16 black button head  
6x M6 black flat washer  
6x M6 flange nut

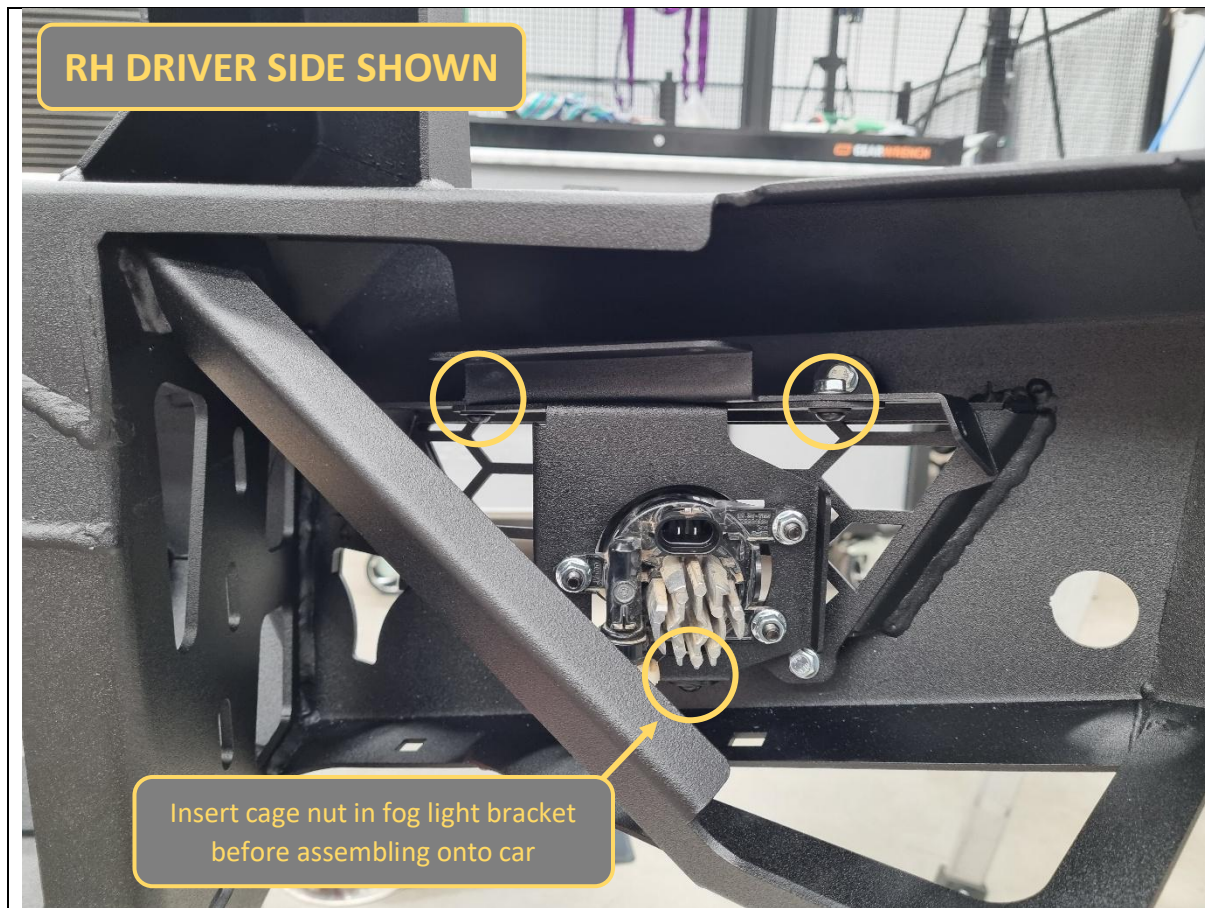

- 105. Insert 1x M6 cage nut in the rectangular slot on the bottom of the fog light bracket. Use a flat blade screwdriver to assist.
- 106. Fit the fog light and bracket to the wing mesh installed on the bull bar.
- 107. Secure with 2x M6x12 black button head bolts, black washers and flange nuts at the top.
- 108. Secure with 1x M6x12 black button head bolt and black washer into the cage nut at the bottom.

**TOOLS REQUIRED**

- Flat blade screwdriver
- 4mm hex/Allen key

**FASTENERS**

- 3x M6x12 black button head
- 3x M6 black washer
- 2x M6 flange nut
  
- 1x M6 cage nut  
(to suit 2mm sheet metal)



109. Instead of fog lights, there is also the option to fit an 8" light bar or up to two 2"x2" cube lights in each wing mesh.

Only one 2"x2" cube light can be fitted if indicator repeaters are present.

Or you can fit no lights at all.

**Note:** Stedi C4 cube lights require spacers to sit at the right height. Offroad Animal cube lights fit without modification.

**TOOLS REQUIRED**

Supplied with accessories

**FASTENERS**

Supplied with accessories



110. Unclip the middle parking sensors and loom from the bumper trim panel.

**TOOLS REQUIRED**

**FASTENERS**



111. Swap over the rubber isolating rings between the outer and inner parking sensors so that the outer sensors use the smaller diameter (thinner) ring and the inner sensors use the larger diameter (thicker) ring.

**TOOLS REQUIRED**

**FASTENERS**

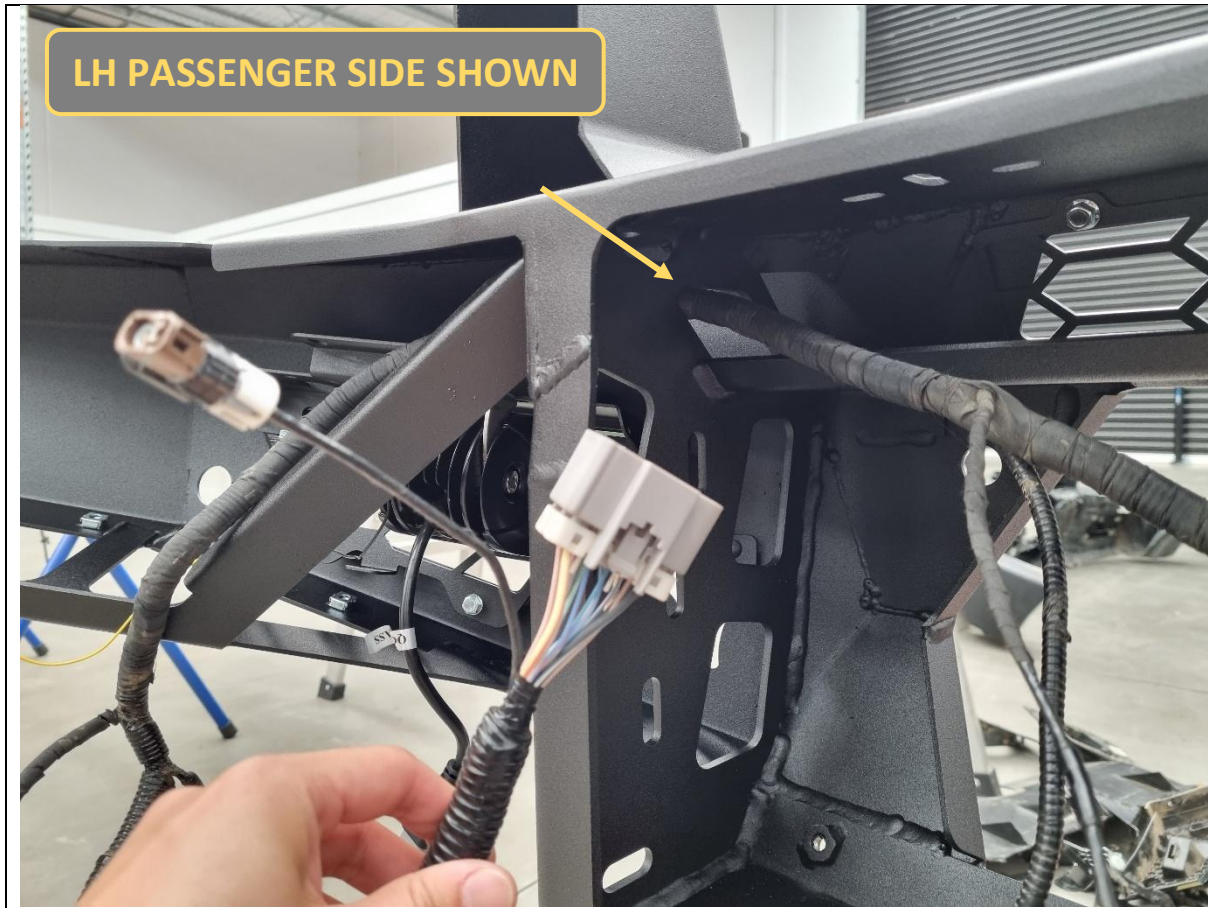

- 112. Route the main bumper harness through the middle of the bull bar, through the cutout as indicated with the arrow.
- 113. Ensure the harness is correctly orientated with the main connector on the LH passenger side, on the outside of the mounting upright.

**TOOLS REQUIRED**

**FASTENERS**



- 114. Fit the front camera into the keyed cutout in the B-1820 camera mount bracket.
- 115. Securely clamp the camera with the B-1821 clamp bracket on the rear with 2x M6x12 black button head bolts, black washers and flange nuts.

**TOOLS REQUIRED**

4mm hex/Allen key

**FASTENERS**

2x M6x12 black button head  
2x M6 black washer  
2x M6 flange nut



- 116. Plug the camera into the loom.
- 117. Fit the camera and mount into the centre of the bull bar.  
  
Route the camera loom through the cutout to the top.
- 118. Secure with 2x M6x16 black button head bolts, black washers and flange nuts.  
  
Have the bolt heads on top as shown.

**TOOLS REQUIRED**

4mm hex/Allen key

**FASTENERS**

2x M6x16 black button head  
2x M6 black washer  
2x M6 flange nut



119. Fit the B-1823 camera cover over the top and secure to the mount bracket with 2x M6x12 black button head bolts, black washers and flange nuts.

Ensure the camera lens is fully poking out the centre hole of the cover.

**TOOLS REQUIRED**

4mm hex/Allen key

**FASTENERS**

2x M6x12 black button head  
2x M6 black washer  
2x M6 flange nut



120. Clean the mounting surfaces of the 4x supplied parking sensor holders and the corresponding mounting locations on the inside of the bull bar with isopropyl alcohol or similar and let it dry.

**TOOLS REQUIRED**

Isopropyl alcohol  
Rag

**FASTENERS**



121. Use the 3M Primer 94 ampule from the parking sensor tape kit and apply primer to all the cleaned surfaces, both on the bull bar and the sensor holders.

**TOOLS REQUIRED**

**FASTENERS**

3M Primer 94

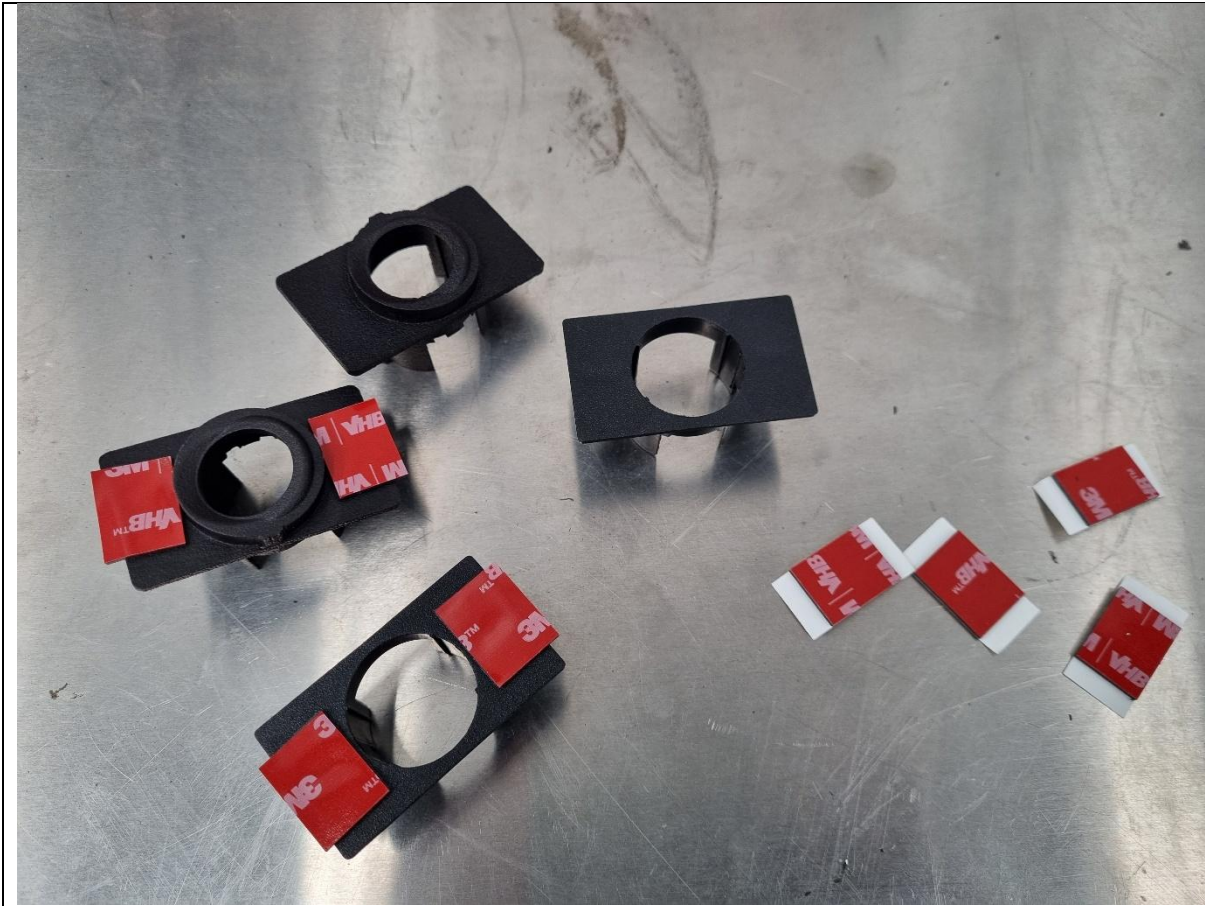

|  |                              |
|--|------------------------------|
| <p><b>Allow at least 5 minutes for the primer to chemically bond to the surfaces before applying tape.</b></p> <p>122. Apply supplied 3M VHB tape from the universal parking sensor tape kit to the parking sensor holders as shown.</p> | <p><b>TOOLS REQUIRED</b></p> |
|  | <p><b>FASTENERS</b></p>      |



123. Clip the F-0030 (flat style) sensor holders into the middle 2x parking sensors.

124. Clip the F-0013R sensor holder in the outer RH parking sensor, and the F-0013L sensor holder in the outer LH parking sensor.

Ensure the rubber isolating ring is seated correctly in the sensor holder and not squished to one side.

**TOOLS REQUIRED**

**FASTENERS**

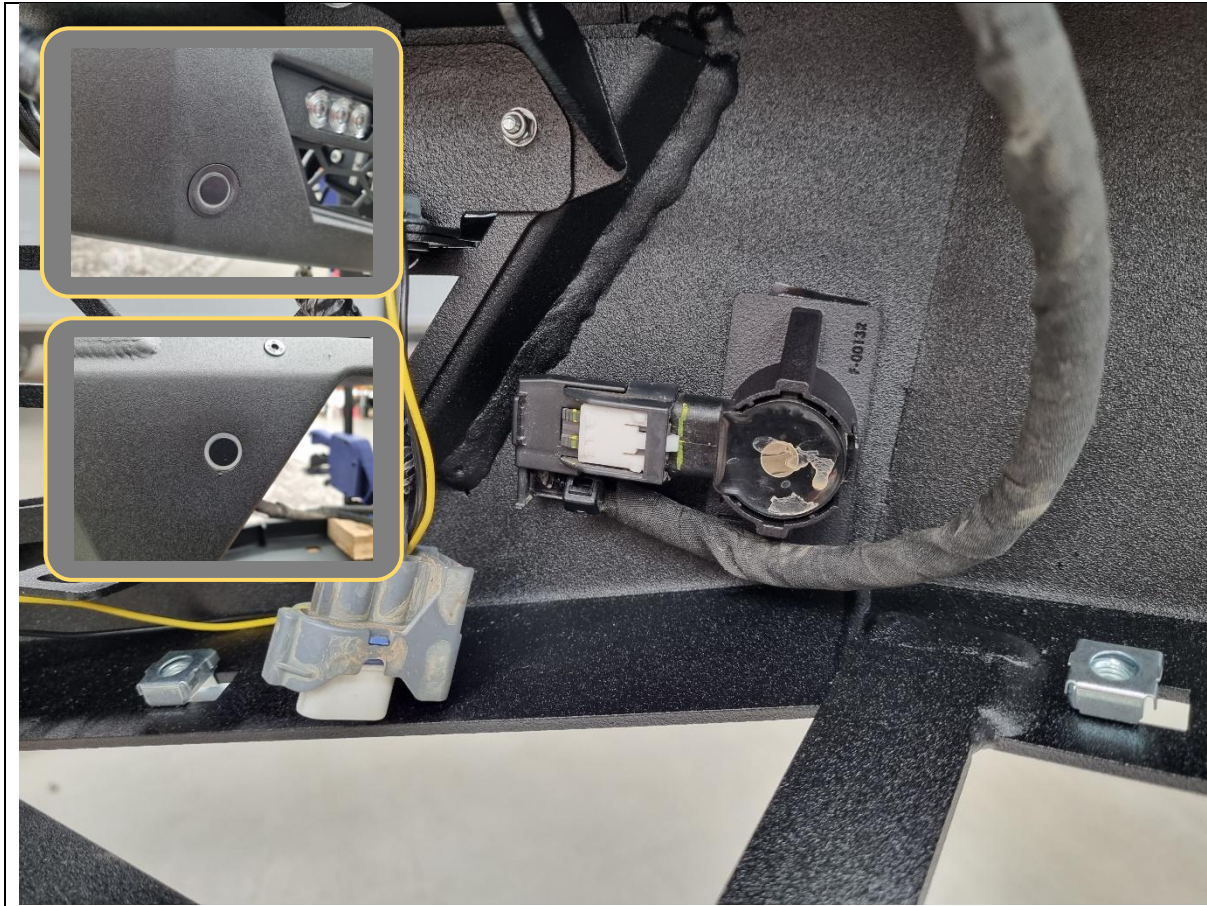

125. Remove the backing film off the tape on the parking sensor holders (use utility knife or 90 degree pick to assist), then fit to their corresponding positions inside the bull bar.

Ensure the rubber isolating ring of the parking sensor fits through the hole in the bar and is not wedged in incorrectly.

126. Ensure the sensor plug orientation matches the installation in the factory bumper (middle sensors pointing outwards, outer sensors pointing inwards towards the centre of the vehicle).

127. Add a pea-sized blob of automotive adhesive sealant (we recommended Sikaflex 227) over the sensor/headlight washer holders and inside face of bar to hold to ensure the tape holds position.

**TOOLS REQUIRED**

Utility knife  
Sikaflex

**FASTENERS**



128. Route the middle parking sensor loom through the side cutout in the bull bar and connect back to the main bumper loom.

**TOOLS REQUIRED**

**FASTENERS**



129. If fitting an integrated light bar, do so now.

This bar is designed to fit the Offroad Animal 22-inch light bar. If fitting this light bar, assemble the light bar with legs facing outwards, and line it up with the slots in the centre gusset. Secure with M6 fasteners supplied with the light.

This bar can accommodate most other “20-22inch” size single row light bars. Stedi ST3K light bars require legs facing inwards.

**TOOLS REQUIRED**

Supplied with accessories

**FASTENERS**

Supplied with accessories



- 130. Fit the pan brace to the back of the light bar mounting area. Route the radar connector through the cutout of the pan brace.
- 131. Secure the pan brace to the top face of the bull bar with 2x M6x16 black button head bolts, black washers and flange nuts.
- 132. Secure the bottom to the embedded nuts in the bull bar with 2x M6x12 hex bolts and flat washers.

**TOOLS REQUIRED**

4mm hex/Allen key  
10mm socket/spanner

**FASTENERS**

2x M6x12 hex bolt  
2x M6 flat washer  
  
2x M6x16 black button head  
2x M6 black washer  
2x M6 flange nut



133. If fitting driving lights, stealth hoop, round hoop or rally hoop to this bar, this is also the most convenient time to do so. It is still possible later, but it is more difficult.

**TOOLS REQUIRED**

Supplied with accessories

**FASTENERS**

Supplied with accessories

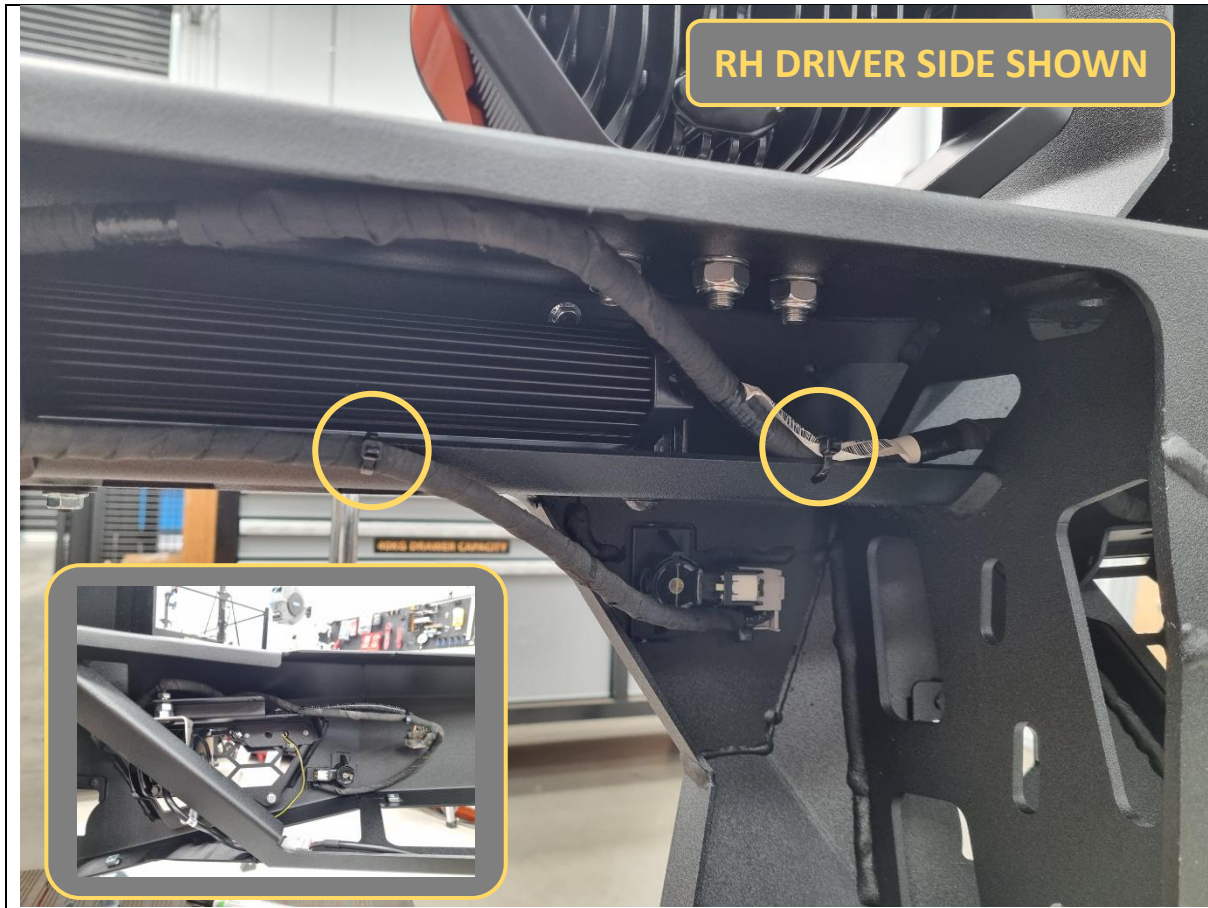

134. Use cable ties and the various holes in the bar and perform cable management on the loom.

**TOOLS REQUIRED**

Cable ties  
Side cutters

**FASTENERS**

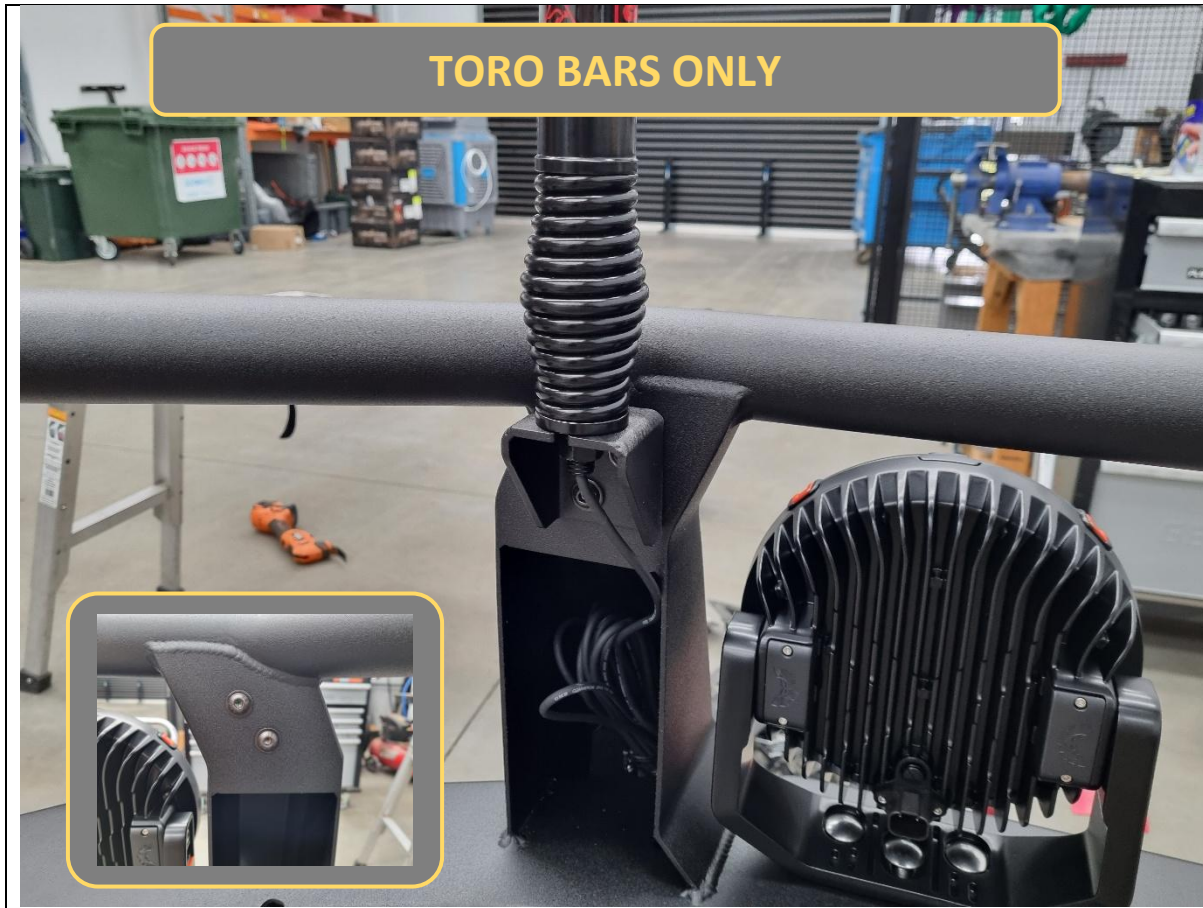

135. **Toro only.** If required, fit the supplied antenna mounting brackets to the back of the bar, and secure with 2x M8x20 black button head bolts and black washers, each.

136. **Toro only.** Else, fit the 2x M8x20 black button head bolts and black washers to the back of each bull bar upright, to protect nut threads in bar for future use.

**TOOLS REQUIRED**

5mm hex/Allen key

**FASTENERS**

4x M8x20 black button head  
4x M8 black flat washer

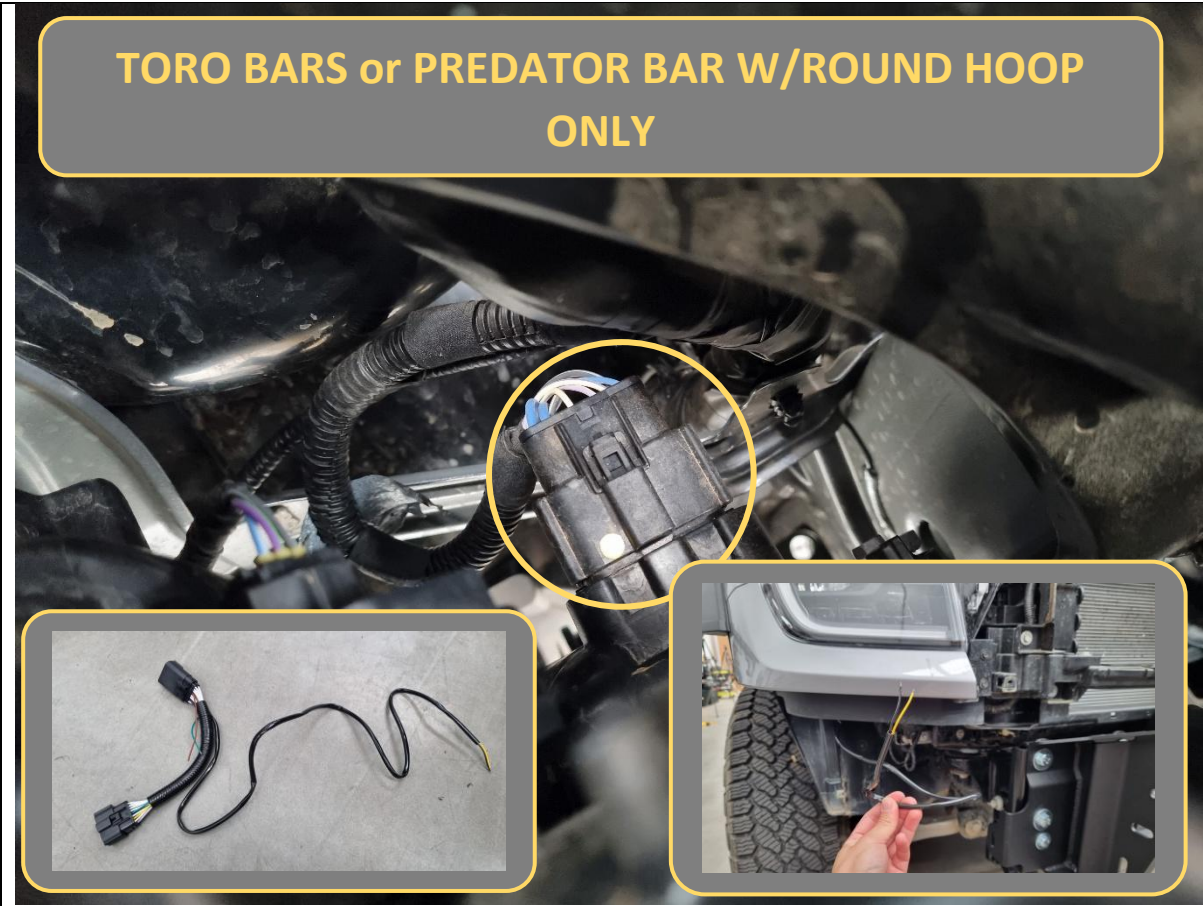

137. For finding the indicator signal for wiring up the indicator repeaters, locate the main headlight plug behind the headlight.

138. You can use the optional Offroad Animal piggyback harness (purchased separately) which will output signal (yellow) and ground (black), otherwise you will need to manually splice into the headlight harness. Consult an automotive electrician if unsure.

139. If using the Offroad Animal piggyback harness, tape off the green and brown high beam trigger wires used on other Ford Ranger headlight models.

As of March 2026, the Super Duty high beam trigger is located in the kick panel in the cab.

**TOOLS REQUIRED**

**FASTENERS**

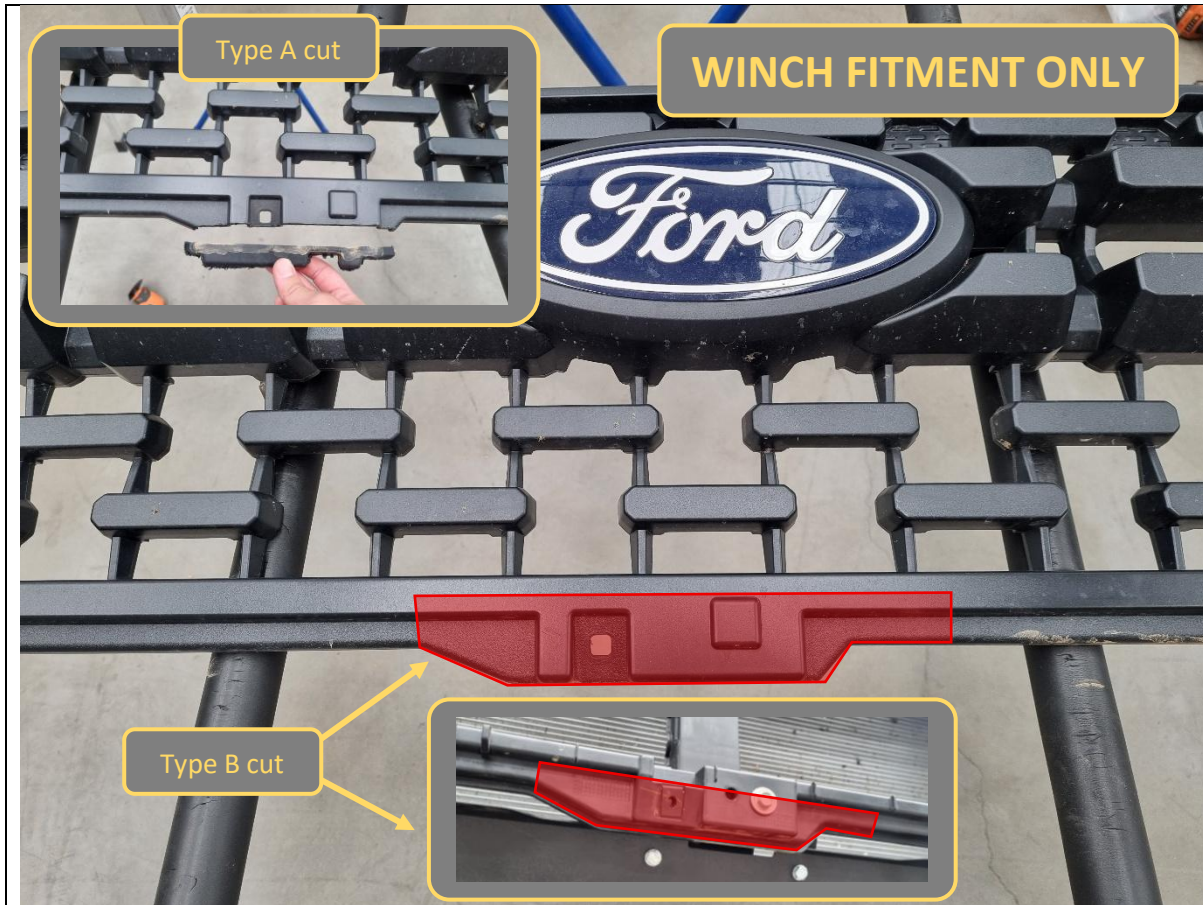

|  |  |
|--|--|
| <p>140. If you are fitting or plan to fit a winch with a top mount control box that is <u>taller than 240mm</u>, you will need to trim off the bottom of the grille and/or support structure.</p> <p>141. Offroad Animal has checked the following winches for compatibility:</p> <ul style="list-style-type: none"> <li>a. Bushranger Covert             <ul style="list-style-type: none"> <li>i. No grille cut required</li> </ul> </li> <li>b. Carbon 12K Winch V3             <ul style="list-style-type: none"> <li>i. No grille cut required for offset box mount</li> <li>ii. Type <u>B</u> cut required for central mount</li> </ul> </li> <li>c. Runva 11EXPEDITION             <ul style="list-style-type: none"> <li>i. Type <u>A</u> cut required</li> </ul> </li> <li>d. Runva 11XP             <ul style="list-style-type: none"> <li>i. No grille cut required for offset box mount</li> <li>ii. Type <u>A</u> cut required for central mount</li> </ul> </li> <li>e. WARN VR EVO             <ul style="list-style-type: none"> <li>i. Type <u>A</u> cut required</li> </ul> </li> <li>f. WARN ZEON             <ul style="list-style-type: none"> <li>i. Type <u>B</u> cut required</li> </ul> </li> </ul> | <p><b>TOOLS REQUIRED</b></p> <p>Multi-tool<br/>or<br/>Similar cutting tool</p> <p>Safety glasses</p> |
|  | <p><b>FASTENERS</b></p>  |

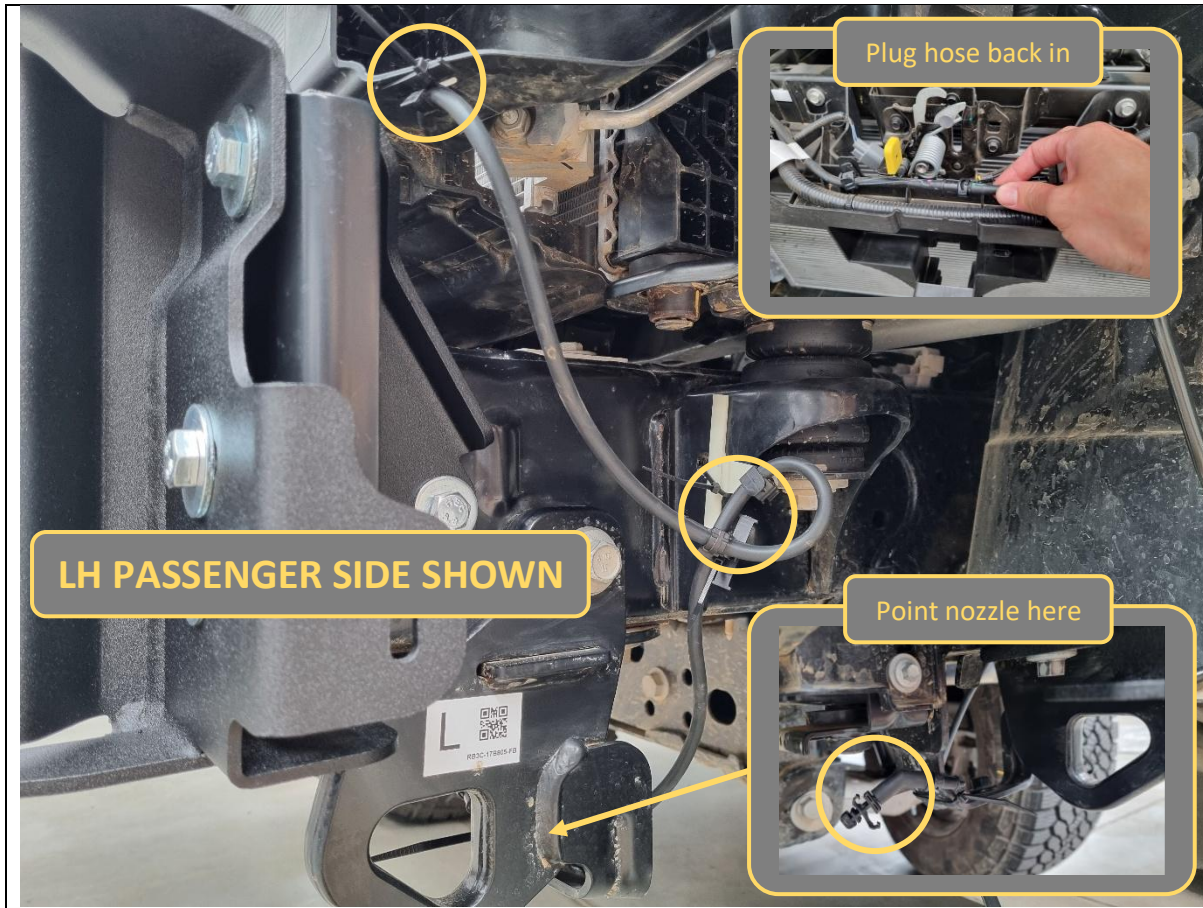

- 142. Plug the washer hose back to the vehicle and remove any hose clamps.
- 143. Route the washer hose down the LH side to the LH recovery point. Water will spray down here instead of onto the camera.
- 144. Reposition the plastic clips attached to the washer hose and cable tie them to vehicle in appropriate locations, such that the rubber washer hose will not rub on anything.

**TOOLS REQUIRED**

- Cable ties
- Side cutters

**FASTENERS**



145. Pre-position the grille back onto the vehicle, but leave the LH unclipped and loose so you can route the main bumper harness back through to the connector up top.

**TOOLS REQUIRED**

**FASTENERS**



- 146. With assistance from other people or a mechanical lift trolley (recommended), bring the bull bar towards the vehicle.
- 147. Route the bumper harness back up behind the grille and plug back in the main bumper and camera connectors.
- 148. Fully press in and clip in the grille once harness is routed through.

**TOOLS REQUIRED**

Lifting trolley

**FASTENERS**



149. Lift the bar onto the mounts on the vehicle.

150. Secure the bar to the mounts with 8x M12x30 bolts, heavy-duty washers and Nyloc + flange nuts. Leave finger tight at this stage.

Note: Use a washer on both bolt and nut side for the Nyloc nut. 1x Nyloc required per side of the bar. 1x washer on the bolt side is all that is required with flange nuts.

**TOOLS REQUIRED**

Lifting trolley

**FASTENERS**

8x M12x30 hex bolt  
10x M12 heavy duty washer  
2x M12 Nyloc nut  
6x M12 flange nut



151. With assistance, from another person, align the bar with the edges of the vehicle. Adjust such that the clearances are neat, and the bar is symmetric left/right on the vehicle.

**Front view:** The bar should sit horizontally level. The top face of the wings should sit just below the bottom edge of the headlights.

**Side view:** The end of the bar wing should be in line with the fold in the flare endcap. There should also be 18-23mm vertical clearance between the top of the bull bar wing and bottom of flare endcap.

**Top view:** There should be around 15mm clearance between the bar and the grille.

152. Once happy with alignment, tighten all 8x M12 bolts.

**TOOLS REQUIRED**

Lifting Trolley

18/19mm socket/spanner

**FASTENERS**

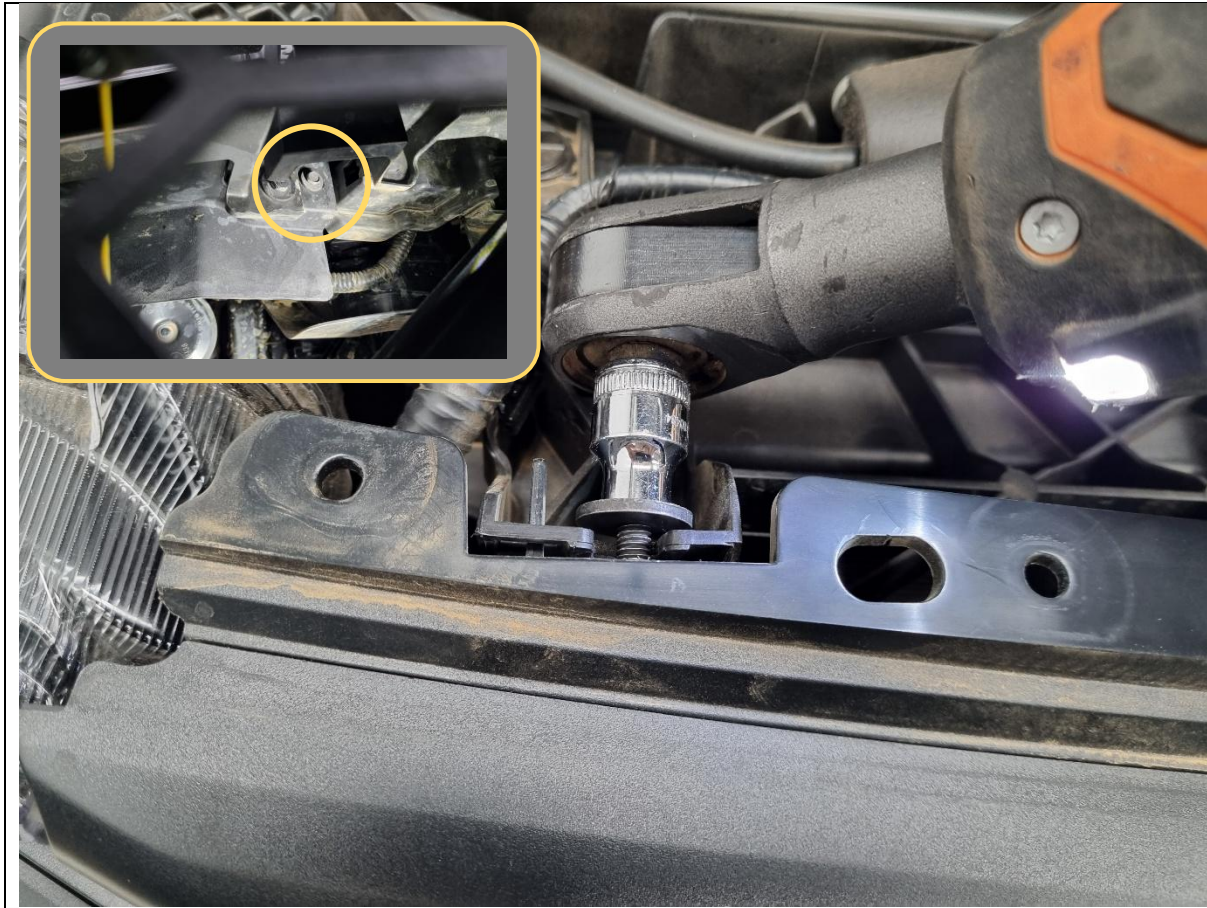

- 153. Re-secure the grille to the vehicle with the factory 8mm hex bolts removed earlier.
- 154. The lower 3x bolts can be accessed from underneath behind the bull bar.
- 155. Skip the middle bolt if that region was cut away for winch clearance.

**TOOLS REQUIRED**

8mm socket/spanner

**FASTENERS**

5x factory 8mm hex bolt

Retained from Step 9

**TORO BARS or PREDATOR BAR W/ROUND HOOP ONLY**



- 156. Connect the indicator repeater wires to the spliced/piggyback wires from the headlight.  
  
Either solder/crimp wires together and electrically insulate the connection afterwards.
- 157. Confirm function of the indicator repeaters by turning on the vehicle hazard lights.  
  
**Do not** turn the vehicle ignition on to test this since the radar is still disconnected. Only use the hazard warning switch.

**TOOLS REQUIRED**

Electrical tools

**FASTENERS**



158. If fitting a winch, do so now.

Ensure the camera, radar and bumper harnesses do not get squished.

This bar is designed to fit most low mount winches, in foot down configuration. WARN ZEON 12 is the largest winch confirmed to fit.

Ensure clutch handle will be accessible through opening in front mesh panel. Refer to winch instructions regarding changing clutch handle location.

**TOOLS REQUIRED**

Refer to instructions supplied by winch

**FASTENERS**

Supplied with winch

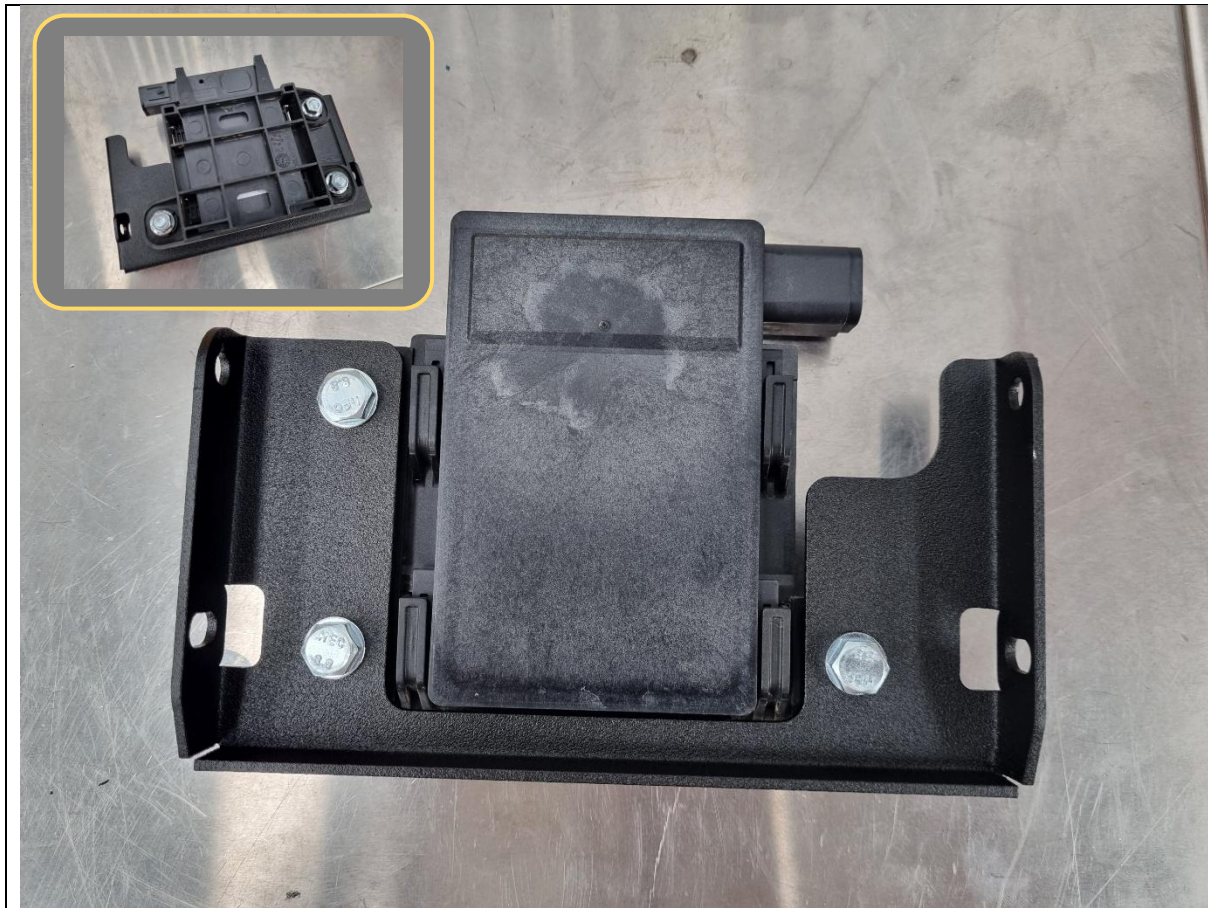

159. Fit the radar to the back of the B-1819 radar bracket and secure with 3x M6x20 hex bolts, flat washers and flange nuts.

**TOOLS REQUIRED**

10mm socket/spanner

**FASTENERS**

3x M6x20 hex bolt  
3x M6 flat washer  
3x M6 flange nut

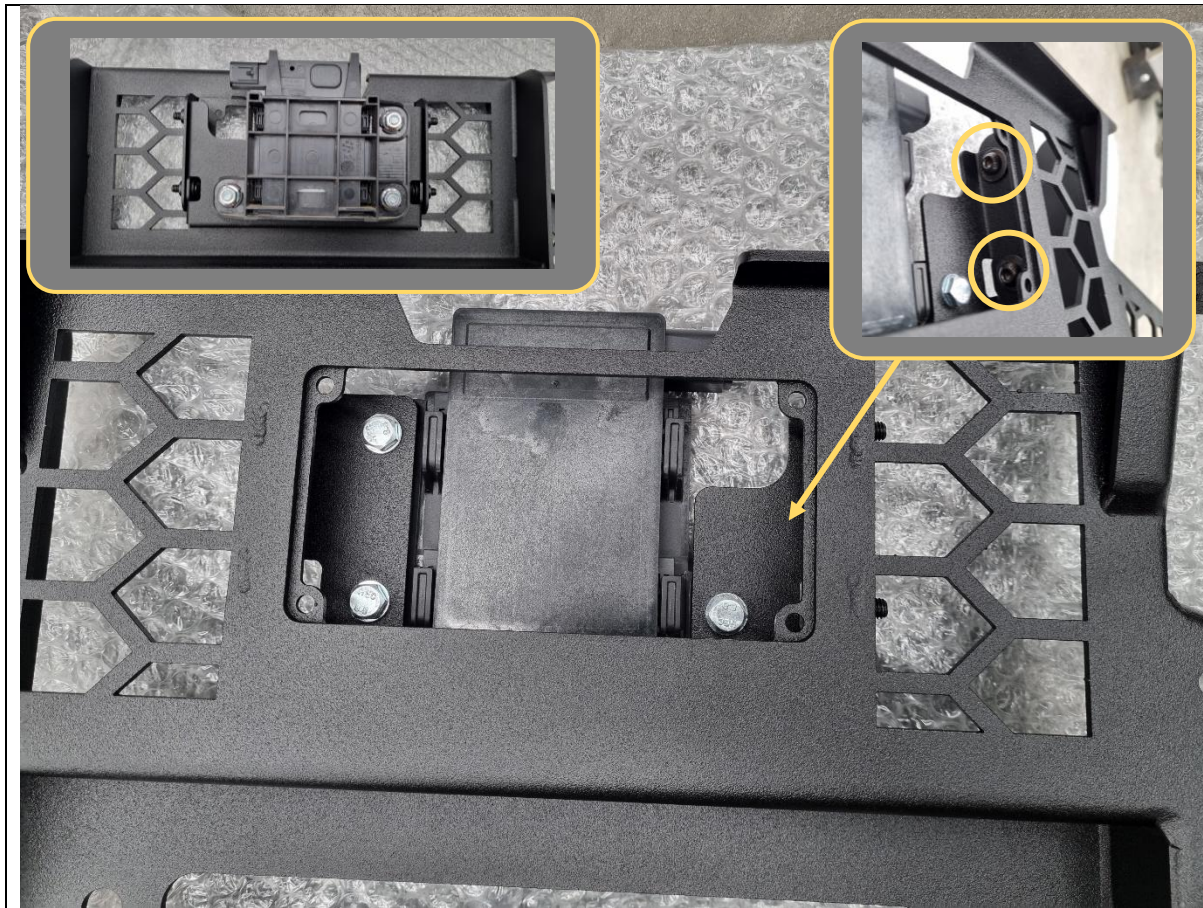

160. Fit the radar with bracket to the back of the centre mesh.
- Ensure the radar is correctly orientated with the plug pointing to the LH passenger side.
161. Finger tight secure the radar bracket to the embedded nuts in the centre mesh using 4x M6x16 black button head bolts and black washers.
- The angle of the radar will be adjusted once fitted to the bull bar and bolts tightened at that stage.

**TOOLS REQUIRED**

4mm hex/Allen key

**FASTENERS**

4x M6x16 black button head  
4x M6 black washer



162. If fitting a winch, fit the hawse fairlead to the centre mesh now using M10 or 3/8" fasteners supplied with the winch. This bar is only compatible with hawse type fairleads.

**TOOLS REQUIRED**

Refer to instructions supplied by winch

**FASTENERS**

Supplied with winch

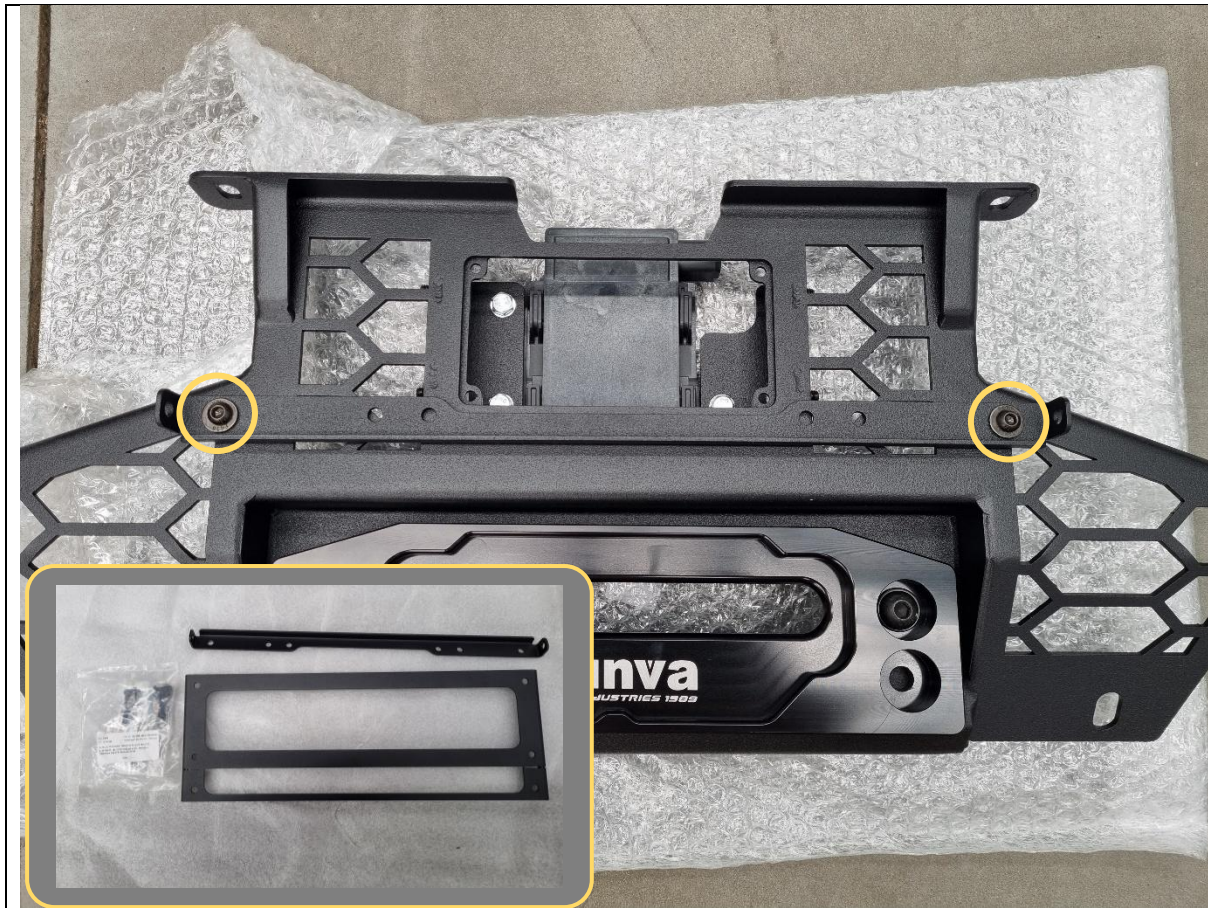

|   |  |
|---|--|
| <p>Locate the number plate flip brackets and fastener kit.</p> <p>163. Fit the base bracket to the centre mesh and secure with 2x M6x16 black button head bolts, black washers and flange nuts.</p> | <p><b>TOOLS REQUIRED</b></p> <p>4mm hex/Allen key</p>  |
|   | <p><b>FASTENERS</b></p> <p>2x M6x16 black button head<br/>2x M6 black flat washer<br/>2x M6 flange nut</p> |

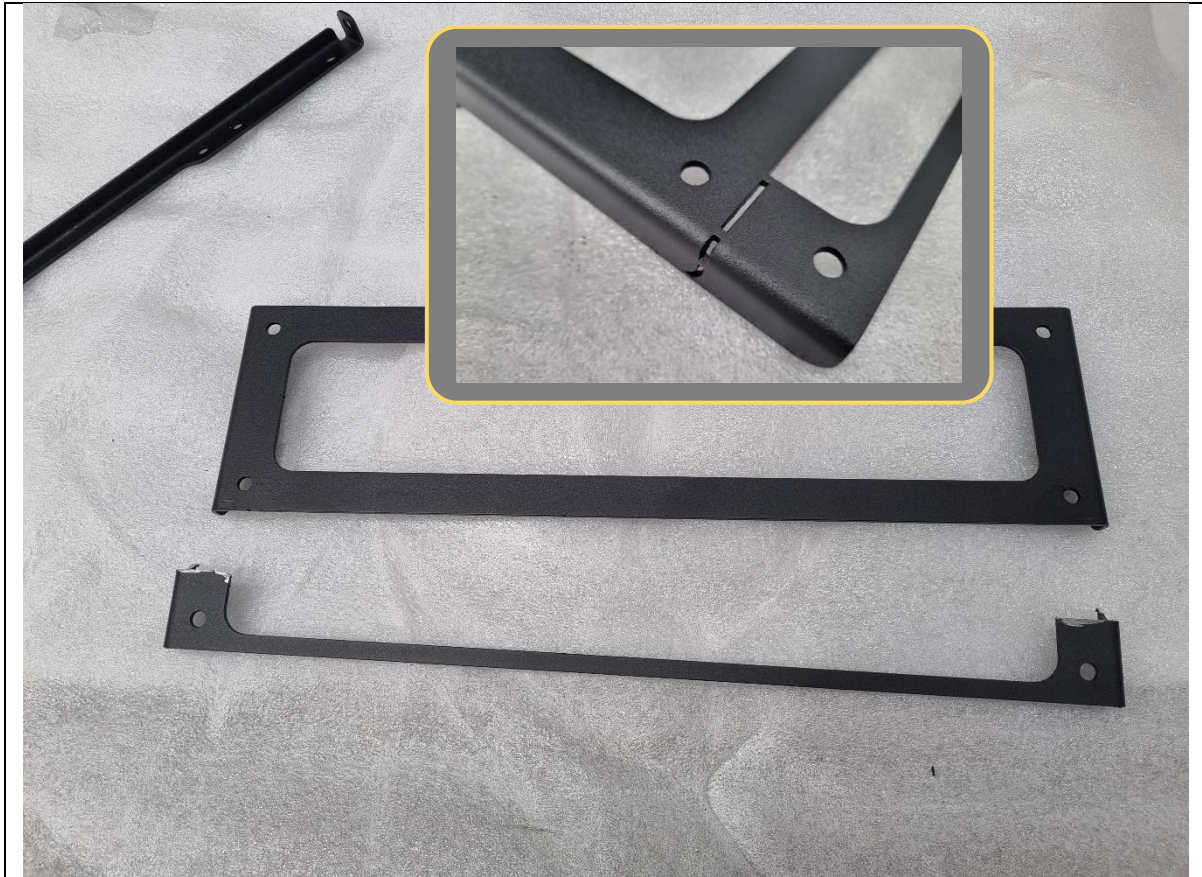

|  |  |
|--|--|
| <p>The number plate flip bracket is designed to be compatible with both standard and slimline number plates.</p> <p>164. If fitting to a slimline plate, use an angle grinder to cut the bottom section of the bracket off along the laser cut grooves.</p> <p>165. Deburr the cut edges, then paint over to prevent rust.</p> | <p><b>TOOLS REQUIRED</b></p> <p>Angle grinder</p> <p>Deburring tool</p> <p>Black spray paint</p> |
|  | <p><b>FASTENERS</b></p>  |



- 166. Fit number plate flip bracket to base bracket as shown above. Tighten bolts so that flip bracket can be moved by hand with some friction resistance.
- 167. Attach number plate to flip bracket using 4x M6x12 black button head bolts, black washers and flange nuts.

**TOOLS REQUIRED**

- 4mm hex/Allen key
- 10mm spanner

**FASTENERS**

- 4x M6x12 black button head
- 2x M6x16 black button head
- 8x M6 black flat washer
- 4x M6 flange nut
- 2x M6 nylon washer
- 2x M6 Nyloc nut



- 168. Present the centre mesh up to the centre opening of the bar. If a winch is fitted, feed the winch rope through the hawse fairlead and fit the winch hook.
- 169. Connect the radar to the bumper harness.
- 170. Secure the centre mesh to the bar using 2x M8x16 black button head bolts + black washers (top), 2x M8x20 hex head bolts + heavy duty washers (bottom).

**TOOLS REQUIRED**

- 13mm socket/spanner
- 5mm hex/Allen key

**FASTENERS**

- 2x M8x16 black button head
- 2x M8 black flat washer
  
- 2x M8x20 hex head
- 2x M8 heavy duty washer



- 171. Hold up a digital angle gauge or other measuring tool to the front face of the radar.
- 172. Adjust the radar so that the radar is sitting 90deg perpendicular to the ground.
- 173. Once aligned, tighten the 4x M6 button head bolts holding the radar (see inset photo).
- 174. Turn the car on test the operation of the radar, camera, parking sensors and fog lights (if fitted).

**TOOLS REQUIRED**

- Digital angle gauge
- 4mm hex/Allen key

**FASTENERS**



175. Fit the supplied plastic N-0027 radar cover panel (textured face on outside) and secure to the centre mesh with 4x fir tree clips supplied.

**TOOLS REQUIRED**

4mm hex/Allen key

**FASTENERS**

4x fir tree clip



176. Re-install the radiator top cover with the 15x scrivets removed earlier and close the bonnet.

**TOOLS REQUIRED**

Phillips head screwdriver

**FASTENERS**

15x scrivets

Retained from Step 8



- 177. Fit the bash plate to the underside of the bull bar.
- 178. Secure to the bull bar at the front with 4x M8x30 black button head bolts and black washers.
- 179. Secure to the impact assemblies at the rear with 2x M10x25 hex bolts, heavy duty washers and flange nuts.

**TOOLS REQUIRED**

5mm hex/Allen key  
16/17mm socket/spanner

**FASTENERS**

4x M8x30 black button head  
4x M8 black flat washer

2x M10x25 hex bolt  
2x M10 heavy duty washer  
2x M10 flange nut



180. Re-fit the factory bash plate with the factory 15mm hex bolts.

**TOOLS REQUIRED**

15mm socket/spanner

**FASTENERS**

2x factory 15mm hex bolt

Retained from Step 17



**RH DRIVER SIDE SHOWN**

181. Peel off the backing film and affix the ADR compliance plate to the inside of the RH side underpanel.

**TOOLS REQUIRED**

**FASTENERS**

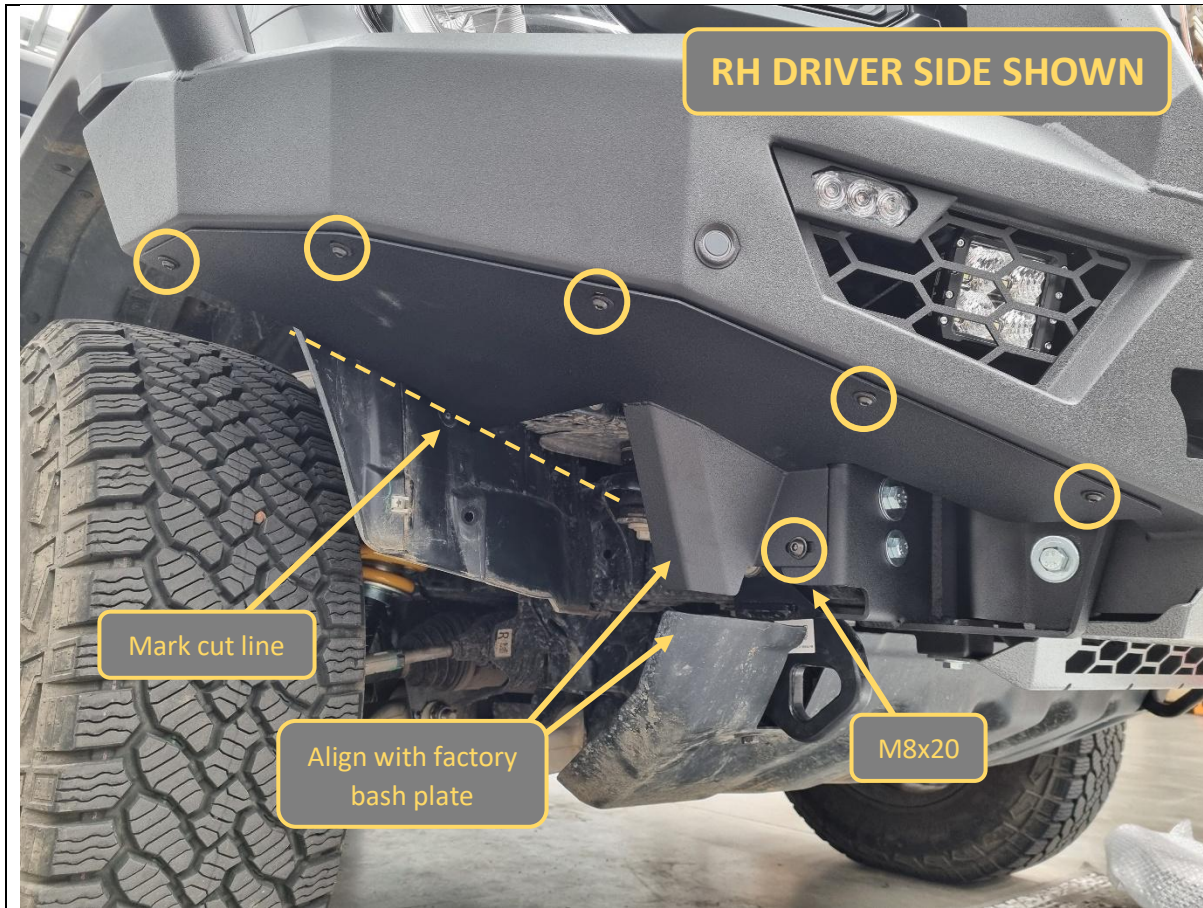

|  |  |
|--|--|
| <p>182. Dry test fit the side underpanels to the underside of the bull bar wings.</p> <p>183. Loosely secure each one with 5x M6x16 black button head bolts and black washers, plus 1x M8x20 black button head bolt, black washer and flange nut.</p> <p>Align the protruding section with the factory bash plate.</p> | <p><b>TOOLS REQUIRED</b></p> <p>4mm hex/Allen key<br/>5mm hex/Allen key</p> <p>Marker pen</p>  |
| <p>184. Using a marker pen, mark out a cut line on the wheel arch liner that matches the bottom profile of the side underpanel.</p>  | <p><b>FASTENERS</b></p> <p>10x M6x16 black button head<br/>10x M6 black flat washer</p> <p>2x M8x20 black button head<br/>2x M8 black flat washer<br/>2x M8 flange nut</p> |



185. Remove the side underpanels, then cut the wheel arch liners along the marked lines.

186. Clean up the cut edge with a deburring tool or similar.

**TOOLS REQUIRED**

Multi-tool  
or  
Similar cutting tool

Safety glasses

Deburring tool

**FASTENERS**



187. Re-fit and fully tighten the side underpanels. Ensure the trimmed wheel arch liner is tucked inside the flanges on the back of the side underpanels.

188. The fitment is now complete. Double check all fasteners are done up.

**TOOLS REQUIRED**

4mm hex/Allen key  
5mm hex/Allen key

**FASTENERS**



**Congratulations! You're done! Get out and tour Australia in your super tough Super Duty!**